

SKADDL

LINEAR MOTOR (English Version)

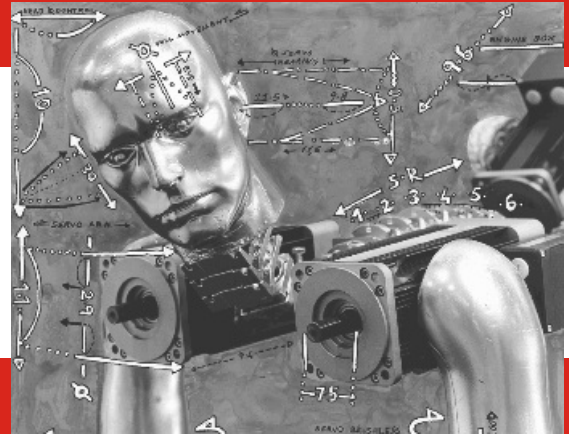
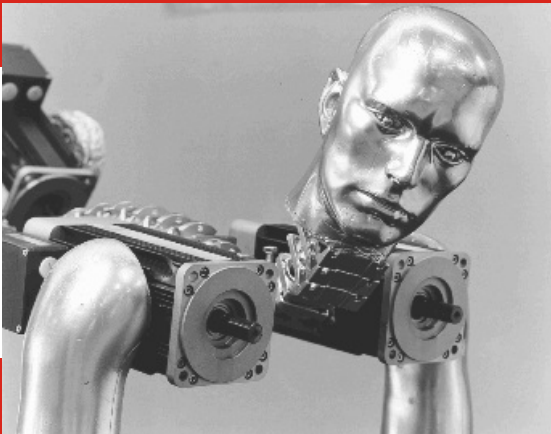

SKADDL

The Ska linear technology, protected by international patents, allows a high performance increasing with an important energy saving. Thanks to the direct mechanical connection to the load to be driven, it is possible to eliminate the kinematic chain. In this way costs and maintenance are reduced and the design of the machine becomes simpler. The system efficiency is high. Speed, acceleration and positioning accuracy values increase.



Self-mounting solution

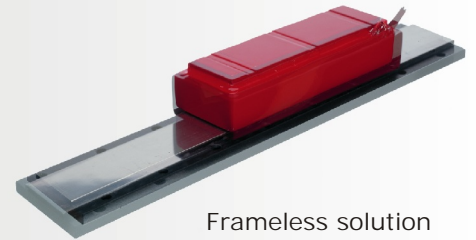

Frameless solution

General features		30HS	55HS	55HM	75HS	75HM	100HS	100HM	125HS	150HS
Peak force	N	450	825	1650	1980	2970	3600	4800	6000	7200
Continuous force*	N	150	275	550	660	990	1200	1600	2000	2400
Magnetic attraction	N	655	1202	2405	3143	4663	5831	7774	9826	11790
Max. speed	m/s	5	5	5	5	5	5	5	5	5
Max. theoretic Acceleration (ref. to the coil)	m/s ²	321	275	240	206	247	200	192	193	194

Overall Dimensions

Coil Length (L)	mm	180	180	350	350	510	535	695	695	695
Coil width (C)	mm	55	80	80	100	100	130	130	155	180
Coil height (B)	mm	47.5	47.5	47.5	51	51	51	51	51	51
Coil weight	Kg	1.4	3	6.9	9.6	12	18	25	31	37
Magnet track width (A)	mm	60	90	90	120	120	140	140	175	200
Magnet track Height (D)	mm	15	15	15	17	17	17	17	17	17
Magnet track weight	Kg/m	4.8	8.5	8.5	13	13	13	15.7	19	22

*Data are rated at $\Delta T = 80^{\circ}C$, $0-40^{\circ}C$ environmental temperature - Class F insulation

*Performances are rated with natural ventilation

Power supply drives: 145Vac, 220Vac, 380Vac

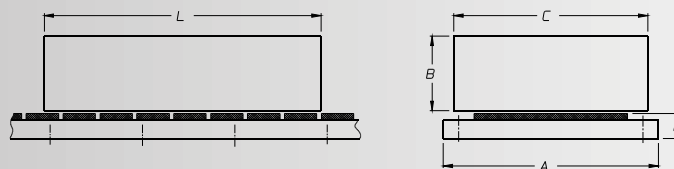

Iron-core synchronous motor

Moving coil insulation class F

Transducers: sin-cos encoder, TTL (optical and magnetic)

Two mounting solutions: frameless and self-sustaining version

Self-sustaining version supplies a complete plug and play system. Temperature sensor, linear ballbearings rail, flexible encoder, cables and cables carrier are included in the motor.

SKA SERIES

SKA Linear Motor , designed and built by Motor Power Company, represents the most recent technological evolution; the revolution of the motion source which has, until now, only been conceived as rotary. Today, thanks to this technology, the performances of a linear mechanical movement have been improved considerably. The kinematic chain is simplified, doing away with the use of mechanical components that until yesterday were essential for transforming rotary motion into linear motion. The SKA iron core brushless motor consists basically of two parts: an a.c. three-phase – the true heart of the linear motor and a magnetic part consisting of a plurality of permanent poles in rare earths.

This series of motors is the result of experience acquired solving real application requirements and of the knowledge of well founded needs. The SKA linear technology, protected by international patents, provide concrete solutions and performances that were impossible with traditional kinematic chains. Its use makes it possible to obtain a considerable improvement of a mechanism's dynamics and allows optimisation of values such as speed, acceleration, positioning precision while simultaneously reducing clearances, friction, delay times and all those losses that occur when a great number of components are used.

Ska Linear Motor combines perfectly with the machine's structure, conforming to the performances required, responding in an appropriate way. To support the product, Motor Power Company is able to understand the application requirements, to respond with concrete solutions, to aid application completely and constantly supplying the product with the configuration most suited to the application and with the most appropriate accessories.

Datasheet n°: 0B0000000401

SKA SERIES

HOW TO ORDER AN IRON CORE LINEAR MOTOR SKA SERIES

SKA	M	55	HS	275	17	01	00	001	01	00	00
SERIES		TYPE	SIZE	RATED FORCE	WINDING CODE	STROKE LENGTH	MAGNETS LENGTH	TRANSDUCER TYPE	OUTPUT CONNECTION	MODELS LIST	
SKA	M = Mounted PP = Power Parts	30* 55 75 100 125 150	HS HM	150* 275 550 660 990 1200 1600 2000 2400	See Data Sheet	See Data Sheet	00 = Mounted version 02= 480mm	007= TTL magnetic encoder 10µm 008= TTL encoder 5µm/P100µm 009= TTL encoder 2,5µm/P100µm 010= TTL encoder 1µm/P100µm	01= Double connector 02= Double cablegland 03= Cable	00 00 =	STD

*Only available in version PP (power parts)

Motor Power Company s.r.l. all rights reserved / The data can be modify without notice

Datasheet n°: 6B3100000401

SKA TRANSDUCCERS

E TYPE: TTL ENCODER

RATED VOLTAGE	Vn	[Vdc]	5 ± 5%
RATED CURRENT	In	[mA]	120
FREQUENCY	F	[kHz]	250
WORKING TEMPERATURE	Tn	[°C]	0 ÷ + 50°
ELECTRONIC TYPE			LINE DRIVER AM 26 LS32
ZERO PULSE			STANDARD
RESOLUTION	A	[μm]	1 - 2.5 - 2 - 5 - 10
ACCURACY		[μm]	± 5 μm/ m
OPTICAL LINE PITCH	P	[μm]	40 - 100 - 200
MAX SPEED	S	[m/s]	2 - 8 - 16

S TYPE: SIN COS ENCODER

RATED VOLTAGE	Vn	[Vdc]	5 ± 5%
RATED CURRENT	In	[mA]	120
FREQUENCY	F	[kHz]	80
WORKING TEMPERATURE	Tn	[°C]	0 ÷ + 50°
SIGNAL TYPE		[Vdc]	1 Vss
ZERO PULSE			STANDARD
RESOLUTION	A	[μm]	Function of the interpolator
ACCURACY		[μm]	± 5 μm/ m
OPTICAL LINE PITCH	P	[μm]	40 - 100 - 200
MAX SPEED	S	[m/s]	3.2 - 5 - 11

EM TYPE: MAGNETIC TTL ENCODER

RATED VOLTAGE	Vn	[Vdc]	5 ± 2.5%
RATED CURRENT	In	[mA]	200
FREQUENCY	F	[kHz]	100
WORKING TEMPERATURE	Tn	[°C]	0 ÷ + 60°
ELECTRONIC TYPE			LINE DRIVER AM 26 LS32
ZERO PULSE			STANDARD
RESOLUTION	A	[μm]	10
ACCURACY		[μm]	± [0.025+(0.02*L)] (L: stroke length in mt)
MAGNETIC TAPE PITCH	P	[mm]	2
MAX SPEED	S	[m/s]	4

Datasheet n°: 2B310000401

SERIES

SKA

30 HS

FORCE [N]

150

SINEWAVE FORM		SYMBOLS	UNITS	TYPE OF WINDING							
				12	14	15	16	17	18		
MOTOR SPEED	Vn drive 145 V (ac) 3phase		[m/s]	4.5	3	2	1.5	1.1			
	Vn drive 220 V (ac) 3phase		[m/s]		4.5	3	2	1.5	1		
	Vn drive 380 V (ac) 3phase		[m/s]			5	4	3	2		
COMMON RATINGS											
	Voltage constant ± 5%	Ke	[Vrms/m/s]	24	36	55	72	97	145		
	Pole pitch	P	[mm]				24				
	Temperature range	Tr	[°C]				0 ÷ 40°				
SKA30 HS 150N											
MOTOR RATINGS	Continuous force(0 m/s)	Fn0	[N]				150				
	Peak force	Fmax	[N]				450				
	Force constant ± 5%	Kf	[N/Arms]	40	60	91	121	161	241		
	Rated current (0 m/s)	In0	[Arms]	3.77	2.5	1.64	1.25	0.933	0.622		
	Peak current	I fmax	[Arms]	15.1	10	6.56	5	3.73	2.49		
	Phase/phase res. ± 5% a 20°C	Rff	[Ohm]	2.24	5	11.74	20.1	36.5	81.6		
	Phase/phase inductance	Lff	[mH]	28.1	53	147.3	252.5	458	1024		
	Electrical time constant	Te	[msec]				12.6				
	Attraction force	Fm	[N]				655				
	Power loss	Pd	[W]				61.8				
	Thermal resistance	Rth	[°C/W]				1.29				
	Motor constant	Km	[N/√W]				21.9				
	SKA30 HS 150N										
	Continuous force(0 m/s)	Fn0	[N]								
	Peak force	Fmax	[N]								
	Force constant ± 5%	Kf	[N/Arms]								
	Rated current (0 m/s)	In0	[Arms]								
	Peak current	I fmax	[Arms]								
	Phase/phase res. ± 5% a 20°C	Rff	[Ohm]								
	Phase/phase inductance	Lff	[mH]								
	Electrical time constant	Te	[msec]								
	Attraction force	Fm	[N]								
	Power loss	Pd	[W]								
	Thermal resistance	Rth	[°C/W]								
	Motor constant	Km	[N/√W]								
THERMAL PROTECTION											
	Type of thermal cut-off			N C : normally closed							
	Rated voltage	Vn	[Vac]	250							
	Rated current	In	[A]	2.5							
	Operative temperature	Tn	[°C]	130 °C ± 5%							
	Resetting temperature	Tr	[°C]	100 °C ± 15°C							
	Operative time		[ms]	1							
	Insulation class			F							

Datasheet n°: 1B3101020401

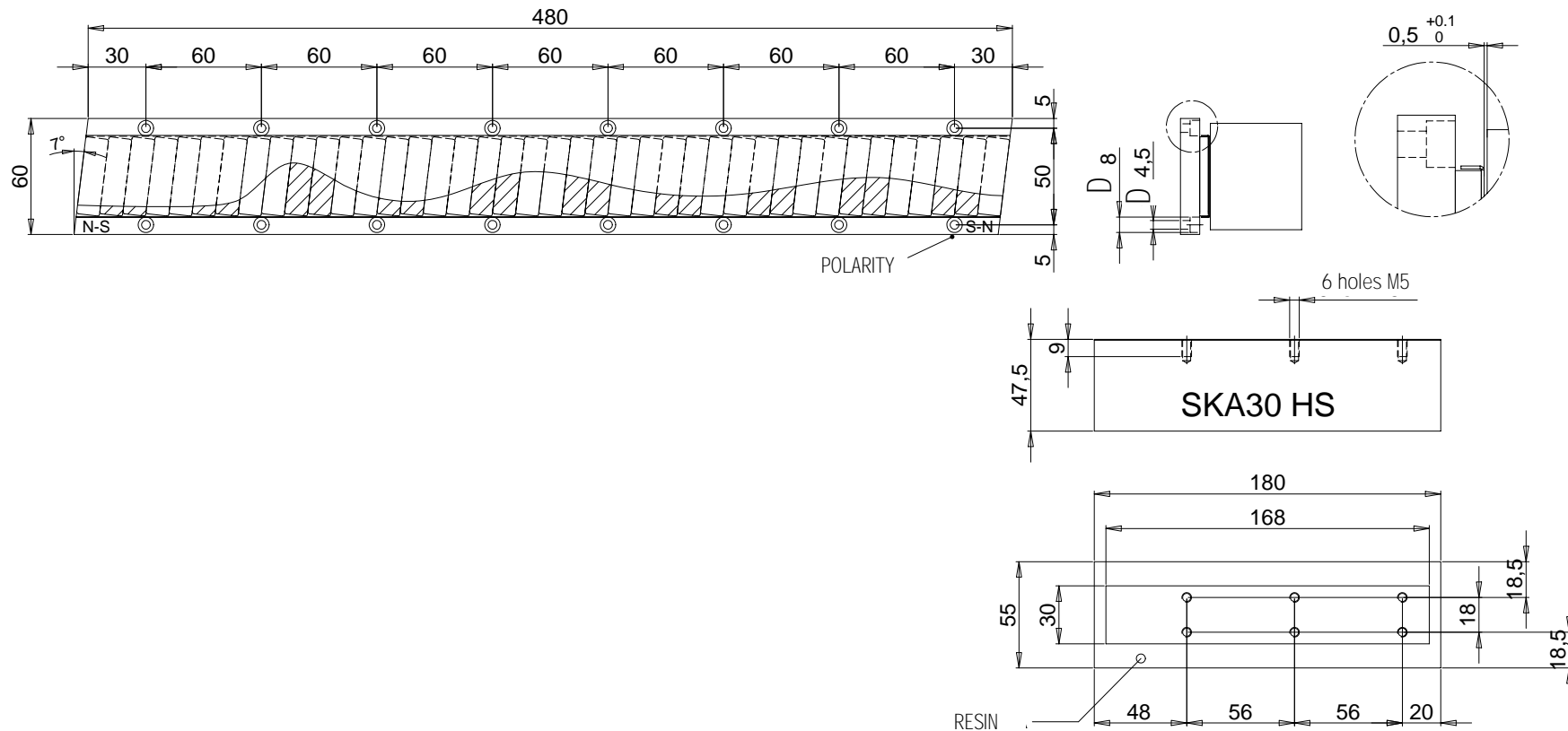

MOTOR POWER COMPANY series **SKA 30 HS** *Power Parts*

MECHANICAL DATA			HS 150
Coil length	L	[mm]	180
Coil width	C	[mm]	55
Coil height	B	[mm]	47.5
Coil weight		[Kg]	1.4
Magnet track width	A	[mm]	60
Magnet track height	D	[mm]	15
Magnet track weight		[kg/m]	4.6
Attraction force		[N]	655
Coil/magnets alignment		[mm]	± 0.3
Connections	U = White - V = Black - W = Red Thermal prot. = Green		

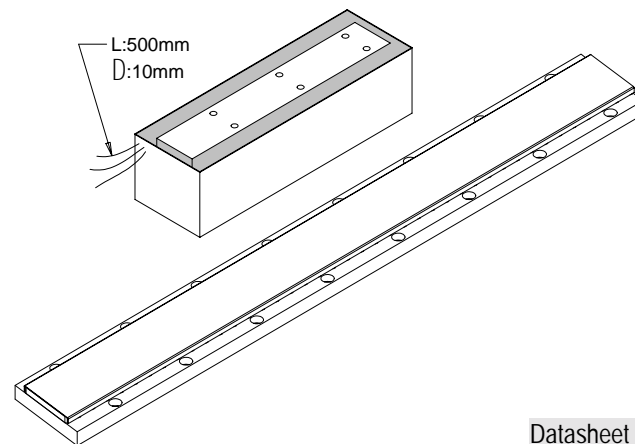

SERIES

SKA

55 HS/HM

FORCE [N]

275/550

SINEWAVE FORM		SYMBOL	UNITS	TYPE OF WINDING							
				12	14	15	16	17	18		
MOTOR SPEED	Vn drive 145 V (ac) 3phase		[m/s]	4.5	3	2	1.5	1.1			
	Vn drive 220 V (ac) 3phase		[m/s]		4.5	3	2	1.5	1		
	Vn drive 380 V (ac) 3phase		[m/s]			5	4	3	2		
COMMON RATINGS											
	Voltage constant ± 5%	Ke	[Vrms/m/s]	24	36	55	72	97	145		
	Pole pitch	P	[mm]				24				
	Temperature range	Tr	[°C]				0 ÷ 40°				
SKA55 HS 275N											
MOTOR RATINGS	Continuous force(0 m/s)	Fn0	[N]				275				
	Peak force	Fmax	[N]				825				
	Force constant ± 5%	Kf	[N/Arms]	40	60	91	121	161	241		
	Rated current (0 m/s)	In0	[Arms]	6.9	4.6	3.0	2.28	1.71	1.14		
	Peak current	I fmax	[Arms]	27.6	18.38	12.0	9.13	6.84	4.56		
	Phase/phase res. ± 5% a 20°C	Rff	[Ohm]	0.933	2.1	4.9	8.4	12.9	34.06		
	Phase/phase inductance	Lff	[mH]	14.8	33.2	77.5	132.8	235.4	538.6		
	Electrical time constant	Te	[msec]				15.8				
	Attraction force	Fm	[N]				1202				
	Power loss	Pd	[W]				86.8				
	Thermal resistance	Rth	[°C/W]				0.921				
	Motor constant	Km	[N/√W]				33.8				
	SKA55 HM 550N										
	Continuous force(0 m/s)	Fn0	[N]				550				
	Peak force	Fmax	[N]				1650				
	Force constant ± 5%	Kf	[N/Arms]	37	56	86	113	151	226		
	Rated current (0 m/s)	In0	[Arms]	14.72	9.8	6.41	4.87	3.65	2.44		
	Peak current	I fmax	[Arms]	58.86	39.2	25.65	19.47	14.59	9.73		
	Phase/phase res. ± 5% a 20°C	Rff	[Ohm]	0.45	0.98	2.33	3.98	7.21	16.21		
	Phase/phase inductance	Lff	[mH]	8.1	18.2	42.5	72.85	131.4	295.5		
	Electrical time constant	Te	[msec]				18.22				
	Attraction force	Fm	[N]				2405				
	Power loss	Pd	[W]				191.5				
	Thermal resistance	Rth	[°C/W]				0.418				
	Motor constant	Km	[N/√W]				45.6				
THERMAL PROTECTION	Type of thermal cut-off			N C : normally closed							
	Rated voltage	Vn	[Vac]	250							
	Rated current	In	[A]	2.5							
	Operative temperature	Tn	[°C]	130 °C ± 5%							
	Resetting temperature	Tr	[°C]	100 °C ± 15°C							
	Operative time		[ms]	1							
	Insulation class			F							

Datasheet n°: 1B3102040401

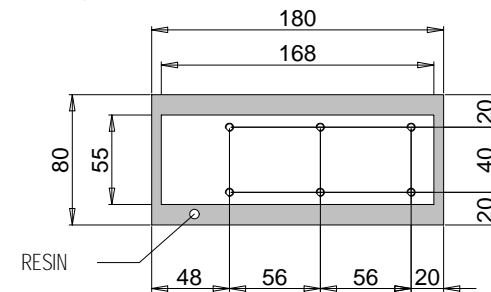
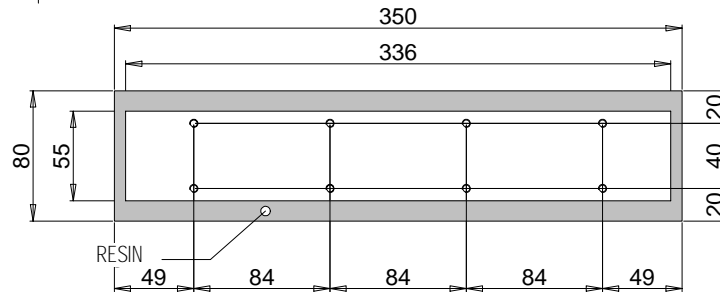
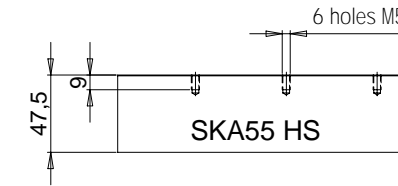
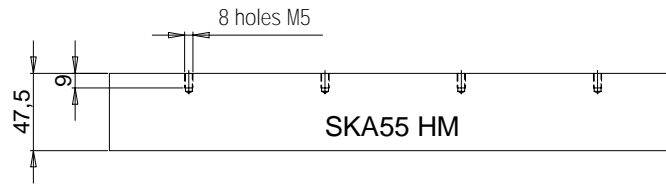
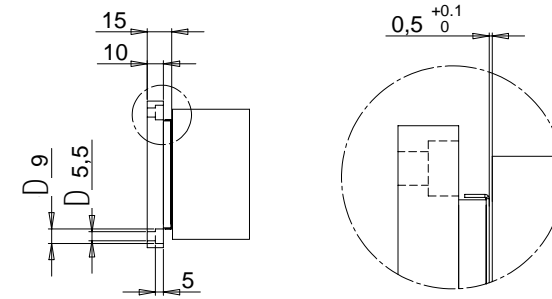
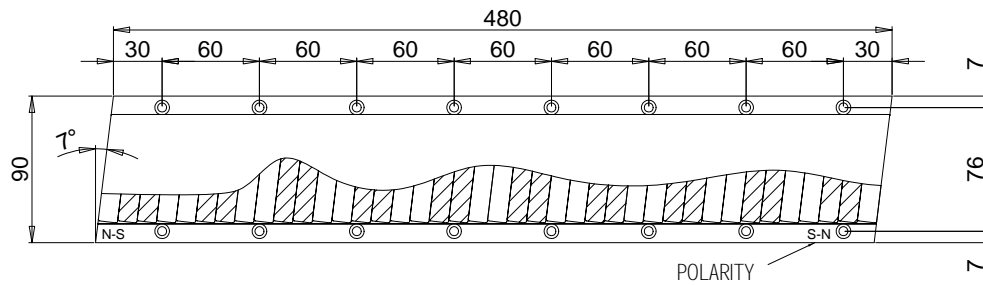

MOTOR POWER COMPANY series
SKA 55 HS/HM Power Parts

MECHANICAL DATA			HS 275	HM 550
Coil length	L	[mm]	180	350
Coil width	C	[mm]	80	80
Coil height	B	[mm]	47.5	47.5
Coil weight		[Kg]	3.0	6.9
Magnet track width	A	[mm]	90	90
Magnet track height	D	[mm]	15	15
Magnet track weight		[kg/m]	8.3	8.3
Attraction force		[N]	1202	2405
Coil/magnets alignment		[mm]	± 0.3	± 0.3
Connections	U = White - V = Black - W = Red Thermal prot. = Green			

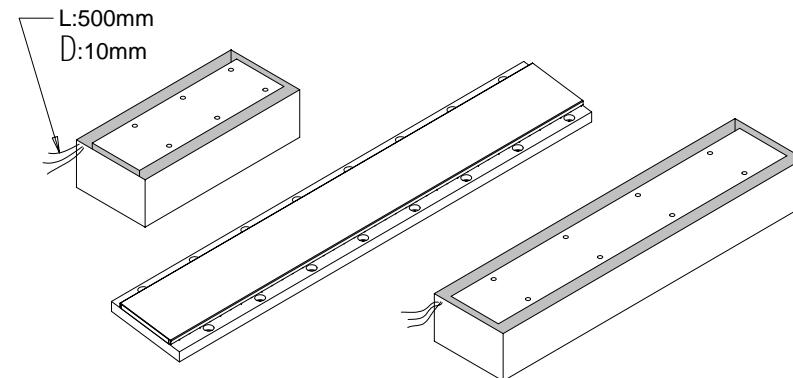

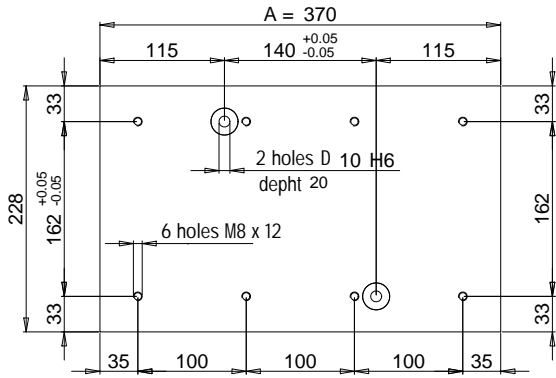

SKA55 HM

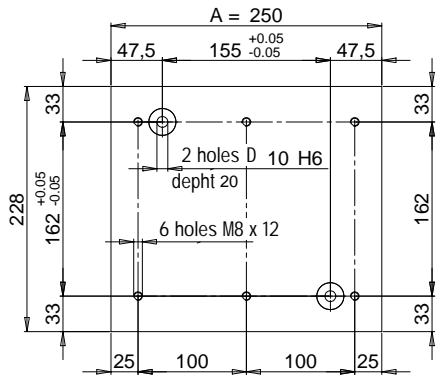

SKA55 HS

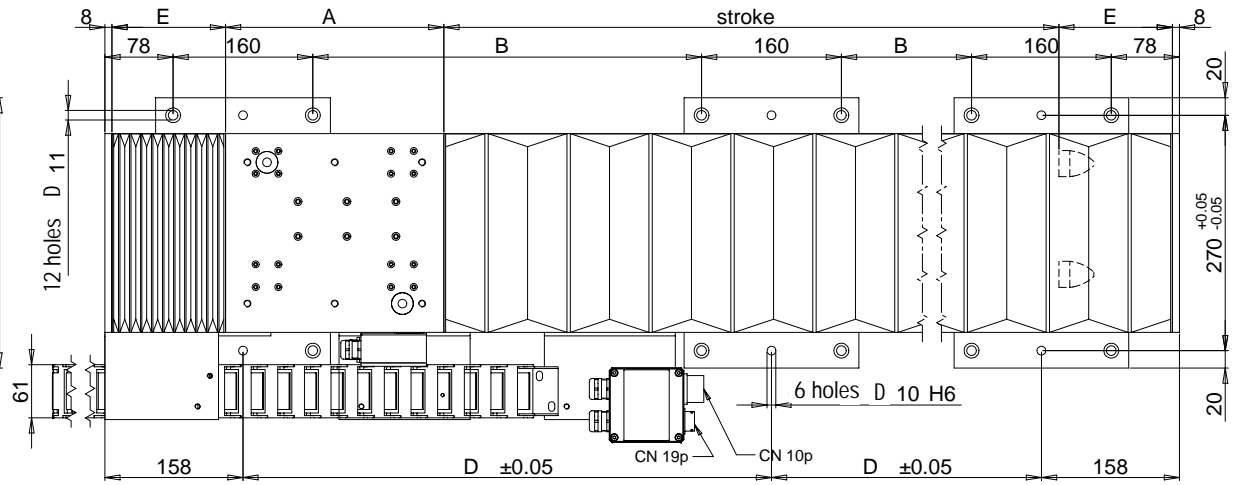
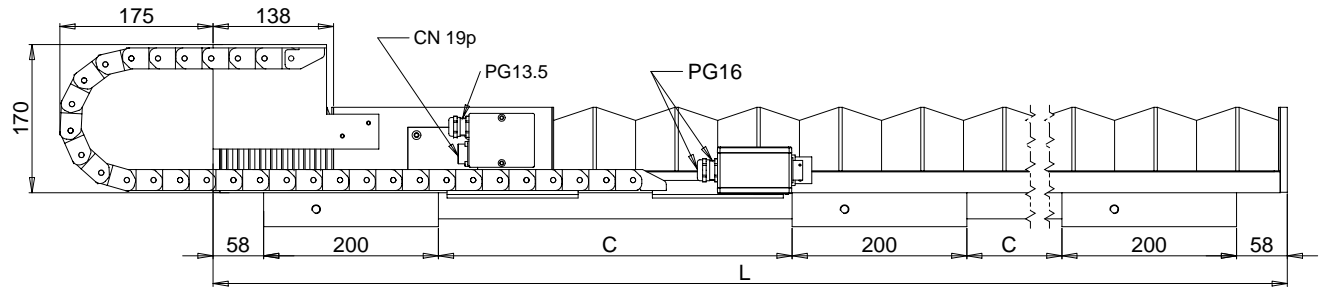
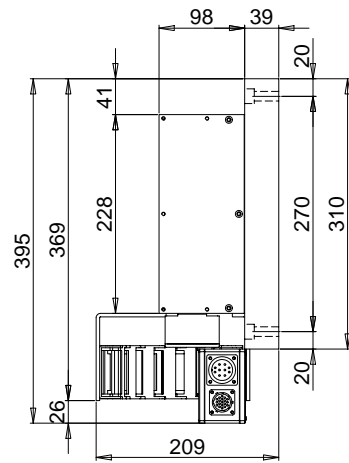

series
SKA 55 HS/HM Complete Servomotor [mm]

Datasheet n°: 7B3102040401

STROKE	500		700		1000		1200		1500		1800		2000		2500		3000	
TYPE	HS	HM	HS	HM	HS	HM	HS	HM	HS	HM	HS	HM	HS	HM	HS	HM	HS	HM
L	996	1116	1196	1316	1526	1646	1786	1906	2146	2266	2526	2646	2766	2886	3366	3486	3986	4106
A	250	370	250	370	250	370	250	370	250	370	250	370	250	370	250	370	250	370
B	180	240	280	340	445	505	575	635	755	815	945	1005	1065	1125	1365	1425	1675	1735
C	140	200	240	300	405	465	535	595	715	775	905	965	1025	1085	1325	1385	1635	1695
D	340	400	440	500	605	665	735	795	915	975	1105	1165	1225	1285	1525	1585	1835	1895
E	115	115	115	115	130	130	160	160	190	190	230	230	250	250	300	300	360	360

SERIES

SKA

75 HS/HM

FORCE [N]

660/990

SINEWAVE FORM		SYMBOL	UNITS	TYPE OF WINDING						
				12	14	15	16	17	18	
MOTR SPEED	Vn drive 145 V (ac) 3phase		[m/s]	4.5	3	2	1.5	1.1		
	Vn drive 220 V (ac) 3phase		[m/s]		4.5	3	2	1.5	1	
	Vn drive 380 V (ac) 3phase		[m/s]			5	4	3	2	
COMMON RATINGS										
	Voltage constant ± 5%	Ke	[Vrms/m/s]	24	36	55	72	97	145	
	Pole pitch	P	[mm]				24			
	Temperature range	Tr	[°C]				0 ÷ 40°			
SKA75 HS 660N										
MOTOR RATINGS	Continuous force(0 m/s)	Fn0	[N]				660			
	Peak force	Fmax	[N]				1980			
	Force constant ± 5%	Kf	[N/Arms]	37	56	86	113	151	226	
	Rated current (0 m/s)	In0	[Arms]	17.66	11.76	7.7	5.85	4.38	2.92	
	Peak current	I fmax	[Arms]	70.6	47	30.78	23.36	17.5	11.7	
	Phase/phase res. ± 5% a 20°C	Rff	[Ohm]	0.37	0.83	1.93	3.31	6.04	13.6	
	Phase/phase inductance	Lff	[mH]	5.7	12.8	30.2	51.5	93.8	210.9	
	Electrical time constant	Te	[msec]				15.4			
	Attraction force	Fm	[N]				3143			
	Power loss	Pd	[W]				229			
	Thermal resistance	Rth	[°C/W]				0.349			
	Motor constant	Km	[N/√W]				50			
	SKA75 HM 990N									
	Continuous force(0 m/s)	Fn0	[N]				990			
	Peak force	Fmax	[N]				2970			
	Force constant ± 5%	Kf	[N/Arms]		56	86	113	151	226	
	Rated current (0 m/s)	In0	[Arms]		17.65	11.54	8.76	6.57	4.38	
	Peak current	I fmax	[Arms]		70.56	46.17	35	26.25	17.52	
	Phase/phase res. ± 5% a 20°C	Rff	[Ohm]		0.57	1.31	2.25	4.05	9.12	
	Phase/phase inductance	Lff	[mH]		8.6	19.9	34.1	61.5	138.4	
	Electrical time constant	Te	[msec]				18.22			
	Attraction force	Fm	[N]				4663			
	Power loss	Pd	[W]				352.8			
	Thermal resistance	Rth	[°C/W]				0.227			
	Motor constant	Km	[N/√W]				60.4			
THERMAL PROTECTION	Type of thermal cut-off			N C : normally closed						
	Rated voltage	Vn	[Vac]	250						
	Rated current	In	[A]	2.5						
	Operative temperature	Tn	[°C]	130 °C ± 5%						
	Resetting temperature	Tr	[°C]	100 °C ± 15°C						
	Operative time		[ms]	1						
	Insulation class			F						

Datasheet n°: 1B3103070401

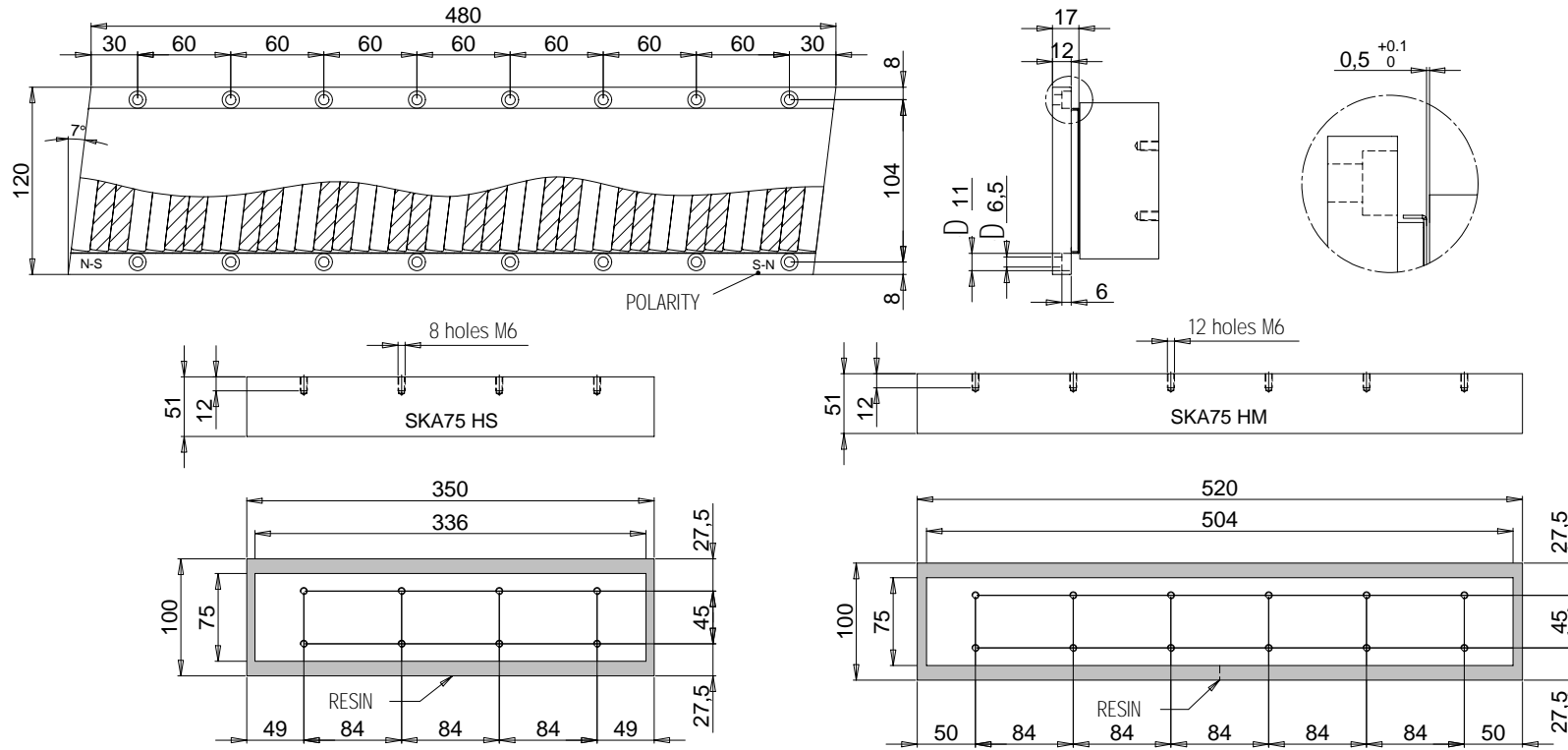

MOTOR POWER COMPANY series
SKA 75 HS/HM Power Parts

MECHANICAL DATA			HS 660	HM 990
Coil length	L	[mm]	350	520
Coil width	C	[mm]	100	100
Coil height	B	[mm]	51	51
Coil weight		[Kg]	9.6	12
Magnet track width	A	[mm]	120	120
Magnet track height	D	[mm]	17	17
Magnet track weight		[kg/m]	13	13
Attraction force		[N]	3143	4663
Coil/magnets alignment		[mm]	± 0.3	± 0.3
Connections	U = White - V = Black - W = Red Thermal prot. = Green			

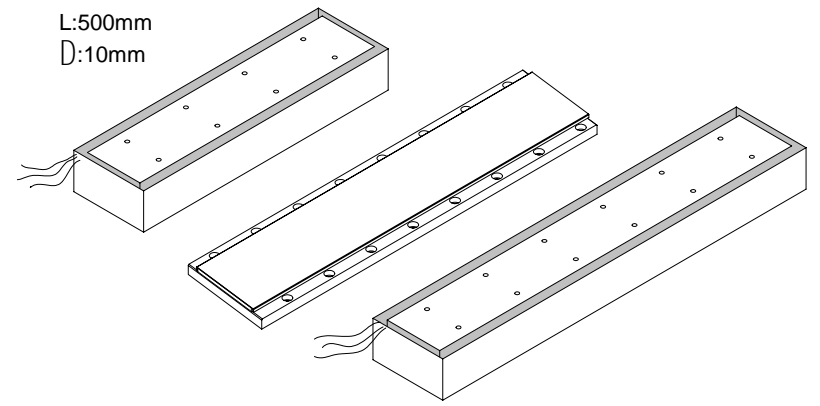

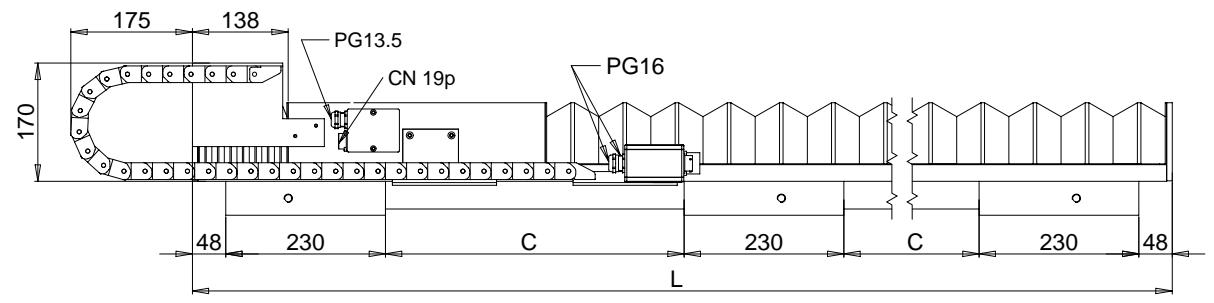
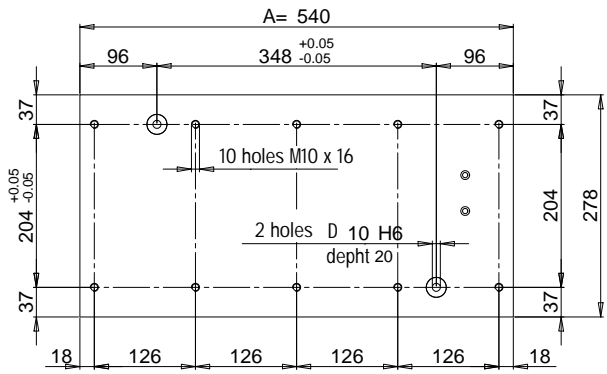

SKA75 HM

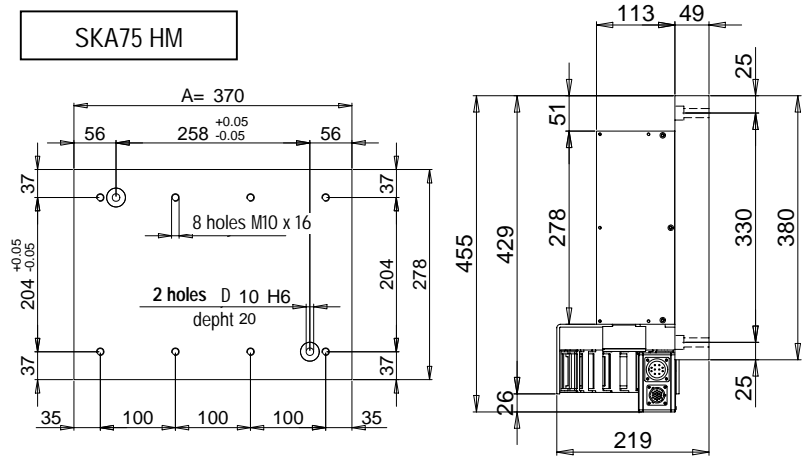

SKA75 HS

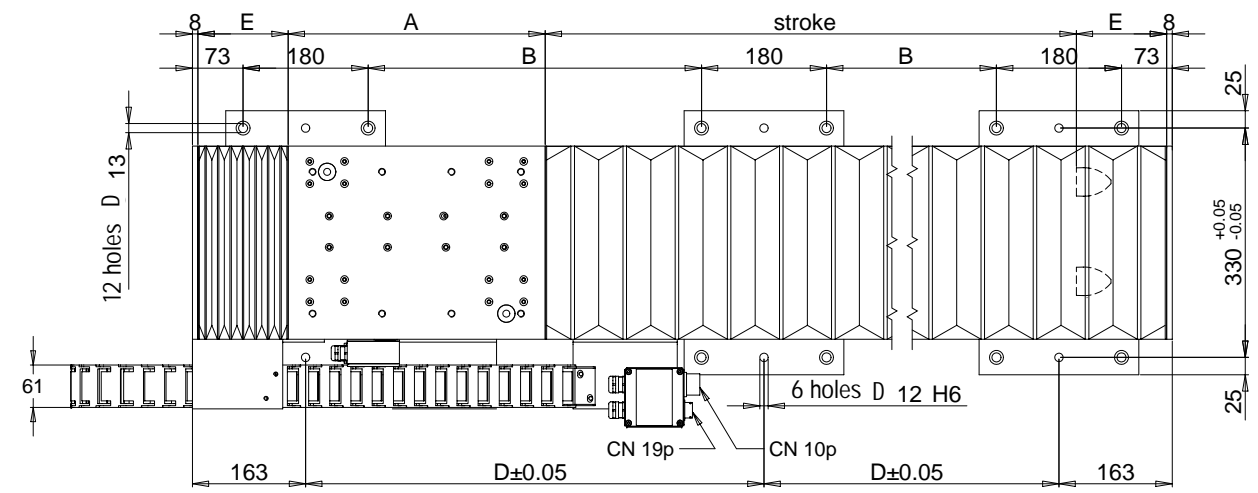

series
SKA 75 HS/HM Complete Servomotor [mm]

Datasheet n°: 7B3103070401

STROKE	500		700		1000		1200		1500		1800		2000		2500		3000	
TYPE	HS	HM	HS	HM	HS	HM	HS	HM	HS	HM	HS	HM	HS	HM	HS	HM	HS	HM
L	1146	1316	1346	1516	1646	1816	1906	2076	2266	2436	2646	2816	2886	3056	3486	3656	4106	4276
A	370	540	370	540	370	540	370	540	370	540	370	540	370	540	370	540	370	540
B	255	340	355	440	505	590	635	720	815	900	1005	1090	1125	1210	1425	1510	1735	1820
C	215	300	315	400	465	550	595	680	775	860	965	1050	1085	1170	1385	1470	1695	1780
D	415	500	515	600	665	750	795	880	975	1060	1165	1250	1285	1370	1585	1670	1895	1980
E	130	130	130	130	130	130	160	160	190	190	230	230	250	250	300	300	360	360

SERIES

SKA

100 HS/HM

FORCE [N]

1200/1600

SINEWAVE FORM		SYMBOL	UNITS	TYPE OF WINDING			
				15	16	17	18
MOTOR SPEED	Vn drive 145 V (ac) 3phase		[m/s]	2	1.5	1.1	
	Vn drive 220 V (ac) 3phase		[m/s]	3	2	1.5	1
	Vn drive 380 V (ac) 3phase		[m/s]	5	4	3	2
COMMON RATINGS							
	Voltage constant ± 5%	Ke	[Vrms/m/s]	55	72	97	145
	Pole pitch	P	[mm]			24	
	Temperature range	Tr	[°C]			0 ÷ 40°	
SKA100 HS 1200N							
MOTOR RATINGS	Continuous force(0 m/s)	Fn0	[N]			1200	
	Peak force	Fmax	[N]			3600	
	Force constant ± 5%	Kf	[N/Arms]	86	113	151	226
	Rated current (0 m/s)	In0	[Arms]	14	10.6	7.96	5.3
	Peak current	I fmax	[Arms]	56	42.5	31.8	21.3
	Phase/phase res. ± 5% a 20°C	Rff	[Ohm]	0.83	1.43	2.56	5.75
	Phase/phase inductance	Lff	[mH]	15.9	27.3	49.2	110.5
	Electrical time constant	Te	[msec]			19	
	Attraction force	Fm	[N]			5831	
	Power loss	Pd	[W]			352	
	Thermal resistance	Rth	[°C/W]			0.227	
	Motor constant	Km	[N/√W]			73.2	
	SKA100 HM 1600N						
	Continuous force(0 m/s)	Fn0	[N]			1600	
	Peak force	Fmax	[N]			4800	
	Force constant ± 5%	Kf	[N/Arms]	84	110	147	221
	Rated current (0 m/s)	In0	[Arms]	19.1	14.5	10.9	7.24
	Peak current	I fmax	[Arms]	74.4	56.5	42.3	28.3
	Phase/phase res. ± 5% a 20°C	Rff	[Ohm]	0.645	1.1	1.92	4.3
	Phase/phase inductance	Lff	[mH]	11.9	21.3	36.9	82.9
	Electrical time constant	Te	[msec]			19.27	
	Attraction force	Fm	[N]			7774	
	Power loss	Pd	[W]			470	
	Thermal resistance	Rth	[°C/W]			0.17	
	Motor constant	Km	[N/√W]			84.6	
THERMAL PROTECTION	Type of thermal cut-off			N C : normally closed			
	Rated voltage	Vn	[Vac]	250			
	Rated current	In	[A]	2.5			
	Operative temperature	Tn	[°C]	130 °C ± 5%			
	Resetting temperature	Tr	[°C]	100 °C ± 15°C			
	Operative time		[ms]	1			
	Insulation class			F			

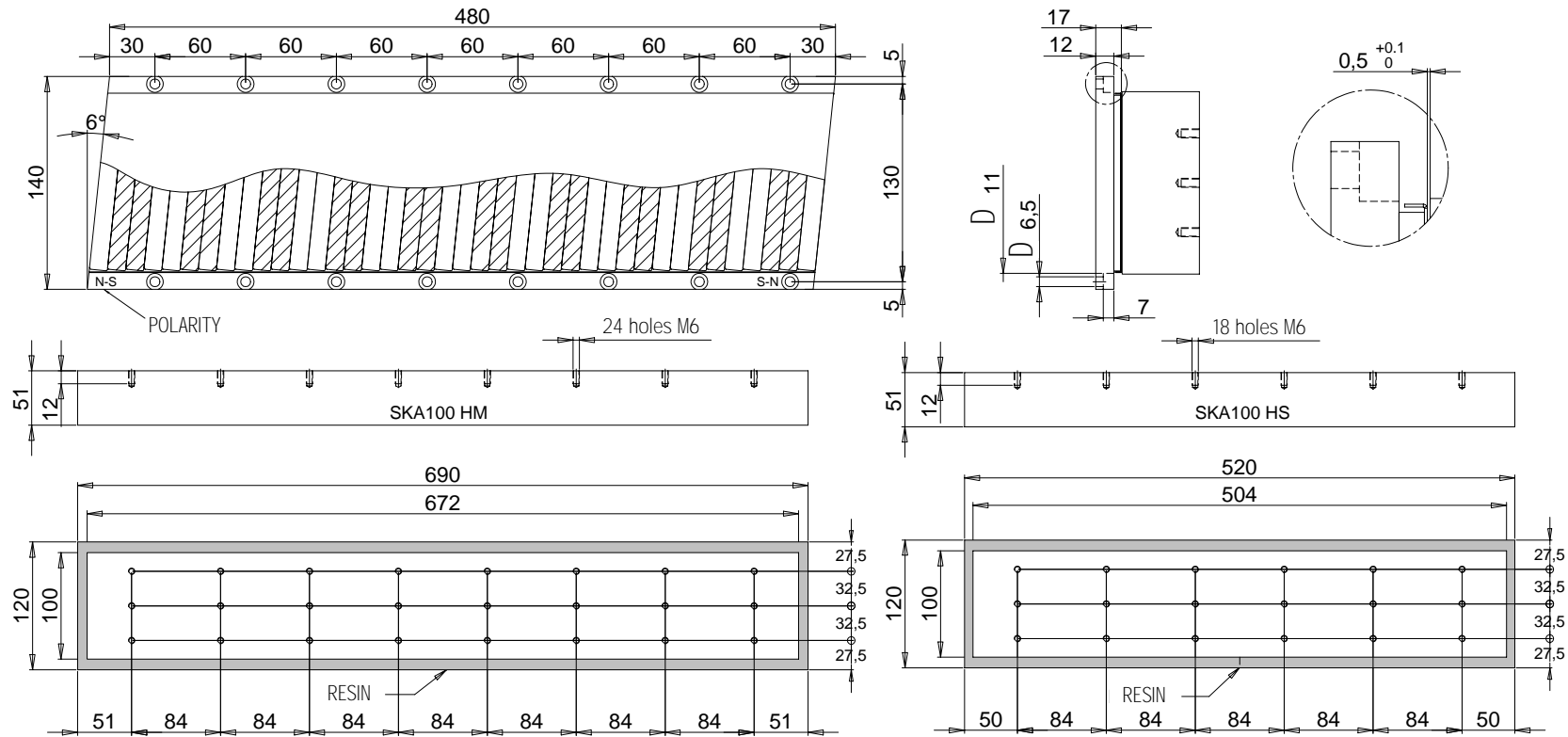

MOTOR POWER COMPANY series
SKA 100 HS/HM *Power Parts*

MECHANICAL DATA			HS 1200	HM 1600
Coil length	L	[mm]	520	690
Coil width	C	[mm]	120	120
Coil height	B	[mm]	51	51
Coil weight		[Kg]	18	25
Magnet track width	A	[mm]	140	140
Magnet track height	D	[mm]	17	17
Magnet track weight		[kg/m]	15.7	15.7
Attraction force		[N]	5831	7774
Coil/magnets alignment		[mm]	± 0.3	± 0.3
Connections	U = White - V = Black - W = Red Thermal prot. = Green			

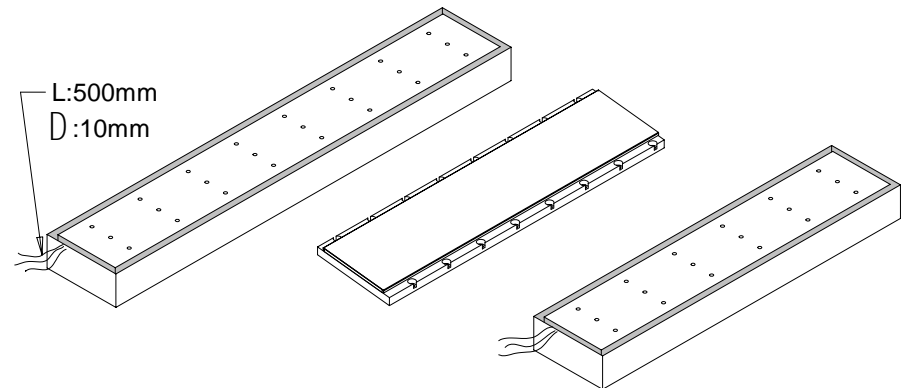

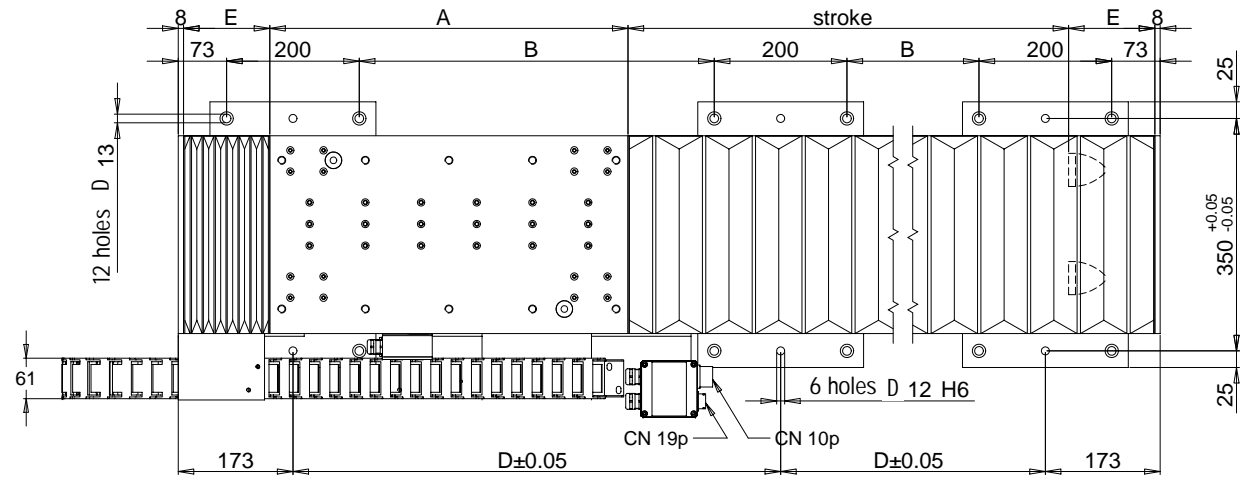
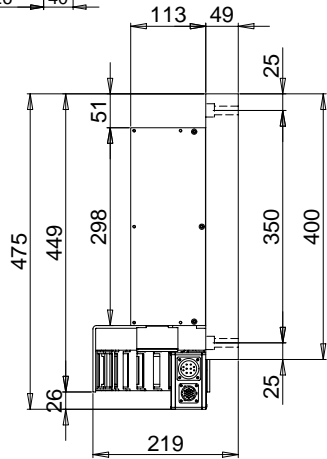
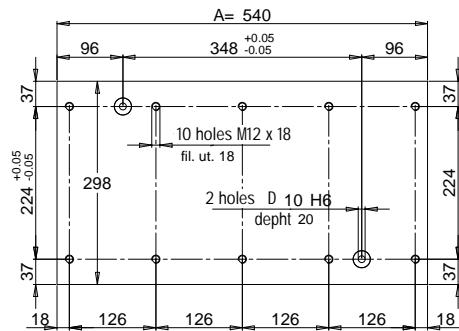
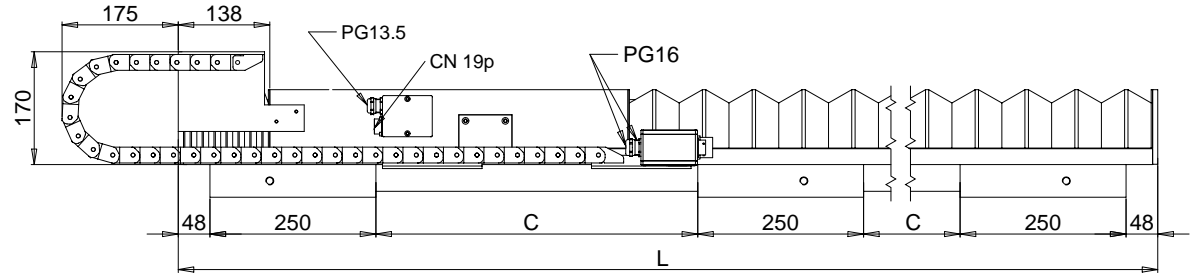
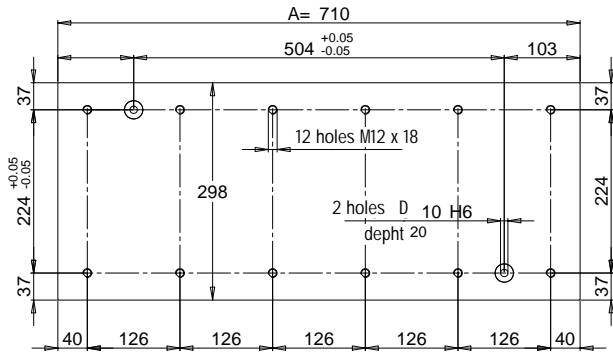

SKA100 HS

MOTOR POWER COMPANY series **SKA 100 HS/HM** Complete Servomotor [mm]

Datasheet n°: 7B3104100401

STROKE	500		700		1000		1200		1500		1800		2000		2500		3000	
TYPE	HS	HM	HS	HM	HS	HM	HS	HM	HS	HM	HS	HM	HS	HM	HS	HM	HS	HM
L	1316	1486	1516	1686	1816	1986	2076	2246	2436	2606	2816	2986	3056	3226	3656	3826	4276	4446
A	540	710	540	710	540	710	540	710	540	710	540	710	540	710	540	710	540	710
B	285	370	385	470	535	620	665	750	845	930	1035	1120	1155	1240	1455	1540	1765	1850
C	235	320	335	420	485	570	615	700	795	880	985	1070	1105	1190	1405	1490	1715	1800
D	485	570	585	670	735	820	865	950	1045	1130	1235	1320	1305	1440	1655	1740	1965	2050
E	130	130	130	130	130	130	160	160	190	190	230	230	250	250	300	300	360	360

SERIES

SKA 125 HS

FORCE [N]

2000

SINEWAVE FORM		SYMBOL	UNITS	TYPE OF WINDING			
				16	17	18	19
MOTR SPEED	Vn drive 145 V (ac) 3phase		[m/s]	1.5	1.1		
	Vn drive 220 V (ac) 3phase		[m/s]	2	1.5	1	
	Vn drive 380 V (ac) 3phase		[m/s]	4	3	2	1.2
COMMON RATINGS							
	Voltage constant ± 5%	Ke	[Vrms/m/s]	72	97	145	242
	Pole pitch	P	[mm]			24	
	Temperature range	Tr	[°C]			0 ÷ 40°	
SKA100 HS 2000N							
MOTOR RATINGS	Continuous force(0 m/s)	Fn0	[N]			2000	
	Peak force	Fmax	[N]			6000	
	Force constant ± 5%	Kf	[N/Arms]	113	151	226	369
	Rated current (0 m/s)	In0	[Arms]	18.1	13.57	9.1	5.42
	Peak current	I fmax	[Arms]	70.6	52.9	35.3	21.13
	Phase/phase res. ± 5% a 20°C	Rff	[Ohm]	0.84	1.52	3.42	9.5
	Phase/phase inductance	Lff	[mH]	15.9	28.7	64.8	189.7
	Electrical time constant	Te	[msec]			18.9	
	Attraction force	Fm	[N]			9826	
	Power loss	Pd	[W]			600	
	Thermal resistance	Rth	[°C/W]			0.133	
	Motor constant	Km	[N/√W]			93.6	
	SKA125 HS 2000N						
	Continuous force(0 m/s)	Fn0	[N]			2000	
	Peak force	Fmax	[N]			6000	
	Force constant ± 5%	Kf	[N/Arms]	113	151	226	369
	Rated current (0 m/s)	In0	[Arms]	18.1	13.57	9.1	5.42
	Peak current	I fmax	[Arms]	70.6	52.9	35.3	21.13
	Phase/phase res. ± 5% a 20°C	Rff	[Ohm]	0.84	1.52	3.42	9.5
	Phase/phase inductance	Lff	[mH]	15.9	28.7	64.8	189.7
	Electrical time constant	Te	[msec]			18.9	
	Attraction force	Fm	[N]			9826	
	Power loss	Pd	[W]			600	
	Thermal resistance	Rth	[°C/W]			0.133	
	Motor constant	Km	[N/√W]			93.6	
THERMAL PROTECTION	Type of thermal cut-off			N C : normally closed			
	Rated voltage	Vn	[Vac]	250			
	Rated current	In	[A]	2.5			
	Operative temperature	Tn	[°C]	130 °C ± 5%			
	Resetting temperature	Tr	[°C]	100 °C ± 15°C			
	Operative time		[ms]	1			
	Insulation class			F			

Datasheet n°: 1B3105130401

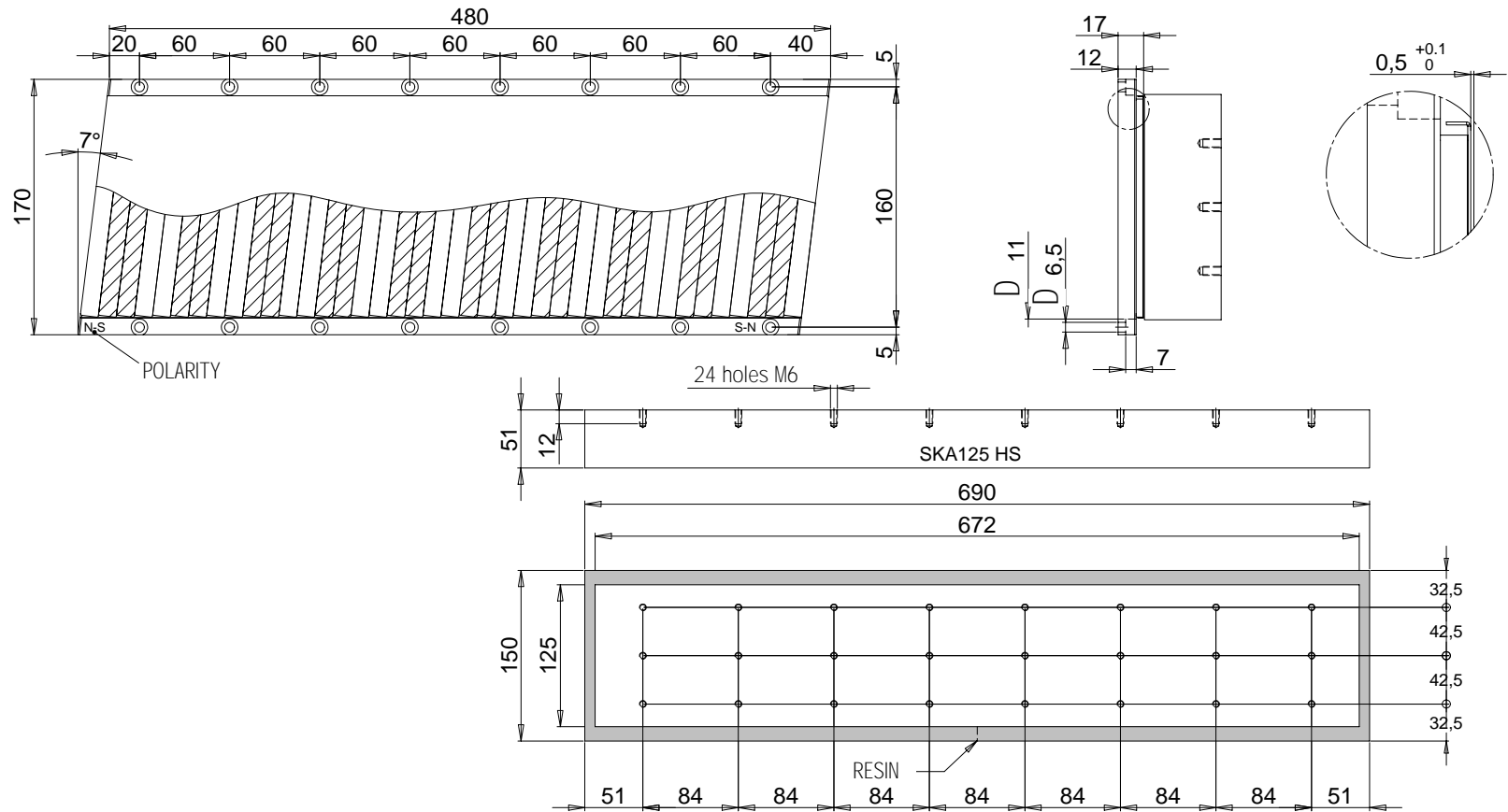

series

SKA 125 HS *Power Parts*

MECHANICAL DATA

			HS 2000
Coil length	L	[mm]	690
Coil width	C	[mm]	150
Coil height	B	[mm]	51
Coil weight		[Kg]	31
Magnet track width	A	[mm]	170
Magnet track height	D	[mm]	17
Magnet track weight		[kg/m]	19
Attraction force		[N]	9826
Coil/magnets alignment		[mm]	± 0.3
Connections	U = White - V = Black - W = Red Thermal prot. = Green		

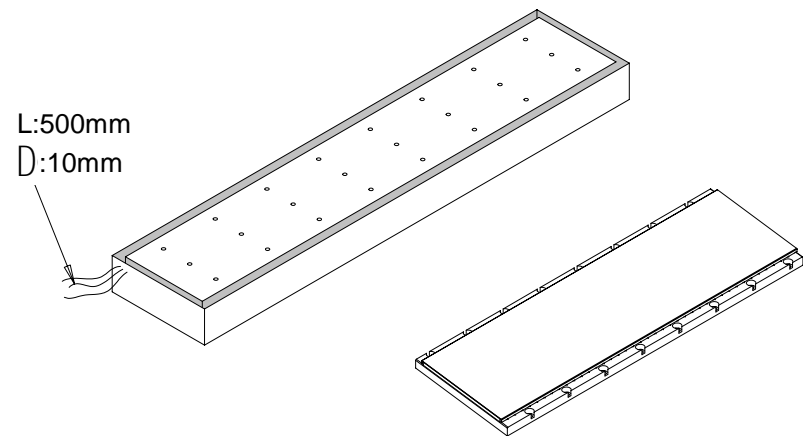

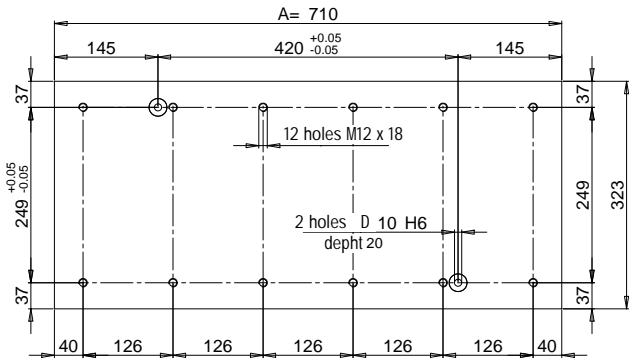

SKA125 HS

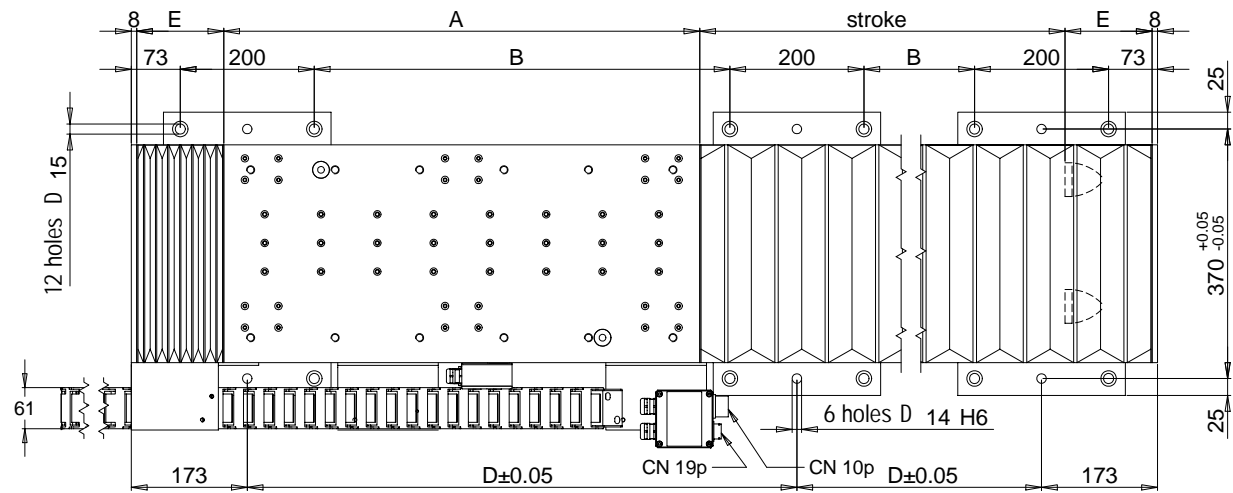
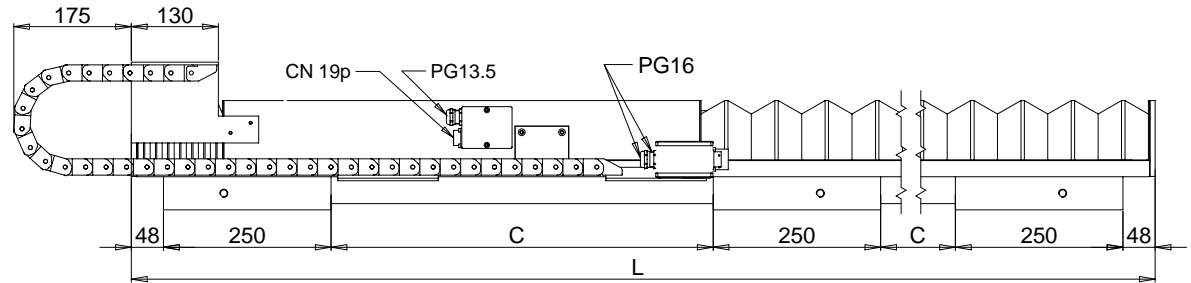
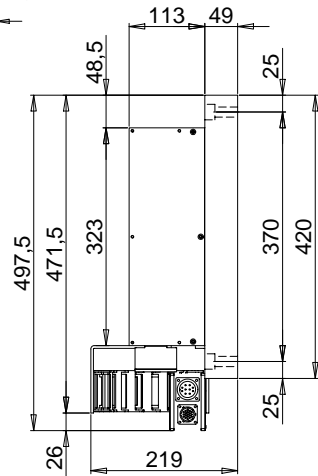

series

SKA 125 HS Complete servomotor [mm]

Datasheet n°: 7B3105130401

STROKE	500	700	1000	1200	1500	1800	2000	2500	3000
TYPE	HS	HS	HS	HS	HS	HS	HS	HS	HS
L	1486	1686	1986	2246	2606	2986	3226	3826	4446
A	710	710	710	710	710	710	710	710	710
B	370	470	620	750	930	1120	1240	1540	1850
C	320	420	570	700	880	1070	1190	1490	1800
D	570	670	820	950	1130	1320	1440	1740	2050
E	130	130	130	160	190	230	250	300	360

SERIES

SKA 150 HS

FORCE [N]

2400

SINEWAVE FORM			SYMBOL	UNITS	TYPE OF WINDING							
					17	18	19					
MOTOR SPEED	Vn drive 145 V (ac) 3phase			[m/s]	1.1							
	Vn drive 220 V (ac) 3phase			[m/s]	1.5	1						
	Vn drive 380 V (ac) 3phase			[m/s]	3	2	1.2					
COMMON RATINGS												
Voltage constant ± 5%			Ke	[Vrms/m/s]	97	145	242					
Pole pitch			P	[mm]		24						
Temperature range			Tr	[°C]		0 ÷ 40°						
SKA150 HS 2400N												
MOTOR RATINGS	Continuous force(0 m/s)			Fn0	[N]		2400					
	Peak force			Fmax	[N]		7200					
	Force constant ± 5%			Kf	[N/Arms]	151	226	369				
	Rated current (0 m/s)			In0	[Arms]	16.27	10.86	6.5				
	Peak current			I fmax	[Arms]	52.9	35.3	25.4				
	Phase/phase res. ± 5% a 20°C			Rff	[Ohm]	1.22	2.74	7.63				
	Phase/phase inductance			Lff	[mH]	25.2	56.6	157.5				
	Electrical time constant			Te	[msec]		20.6					
	Attraction force			Fm	[N]		11790					
	Power loss			Pd	[W]		693					
	Thermal resistance			Rth	[°C/W]		0.115					
	Motor constant			Km	[N/√W]		104.5					
	SKA150 HS 2400N											
	Continuous force(0 m/s)			Fn0	[N]							
	Peak force			Fmax	[N]							
Force constant ± 5%			Kf	[N/Arms]								
Rated current (0 m/s)			In0	[Arms]								
Peak current			I fmax	[Arms]								
Phase/phase res. ± 5% a 20°C			Rff	[Ohm]								
Phase/phase inductance			Lff	[mH]								
Electrical time constant			Te	[msec]								
Attraction force			Fm	[N]								
Power loss			Pd	[W]								
Thermal resistance			Rth	[°C/W]								
Motor constant			Km	[N/√W]								
THERMAL PROTECTION	Type of thermal cut-off				N C : normally closed							
	Rated voltage			Vn	[Vac]	250						
	Rated current			In	[A]	2.5						
	Operative temperature			Tn	[°C]	130 °C ± 5%						
	Resetting temperature			Tr	[°C]	100 °C ± 15°C						
	Operative time				[ms]	1						
Insulation class					F							

Datasheet n°: 1B3106150401

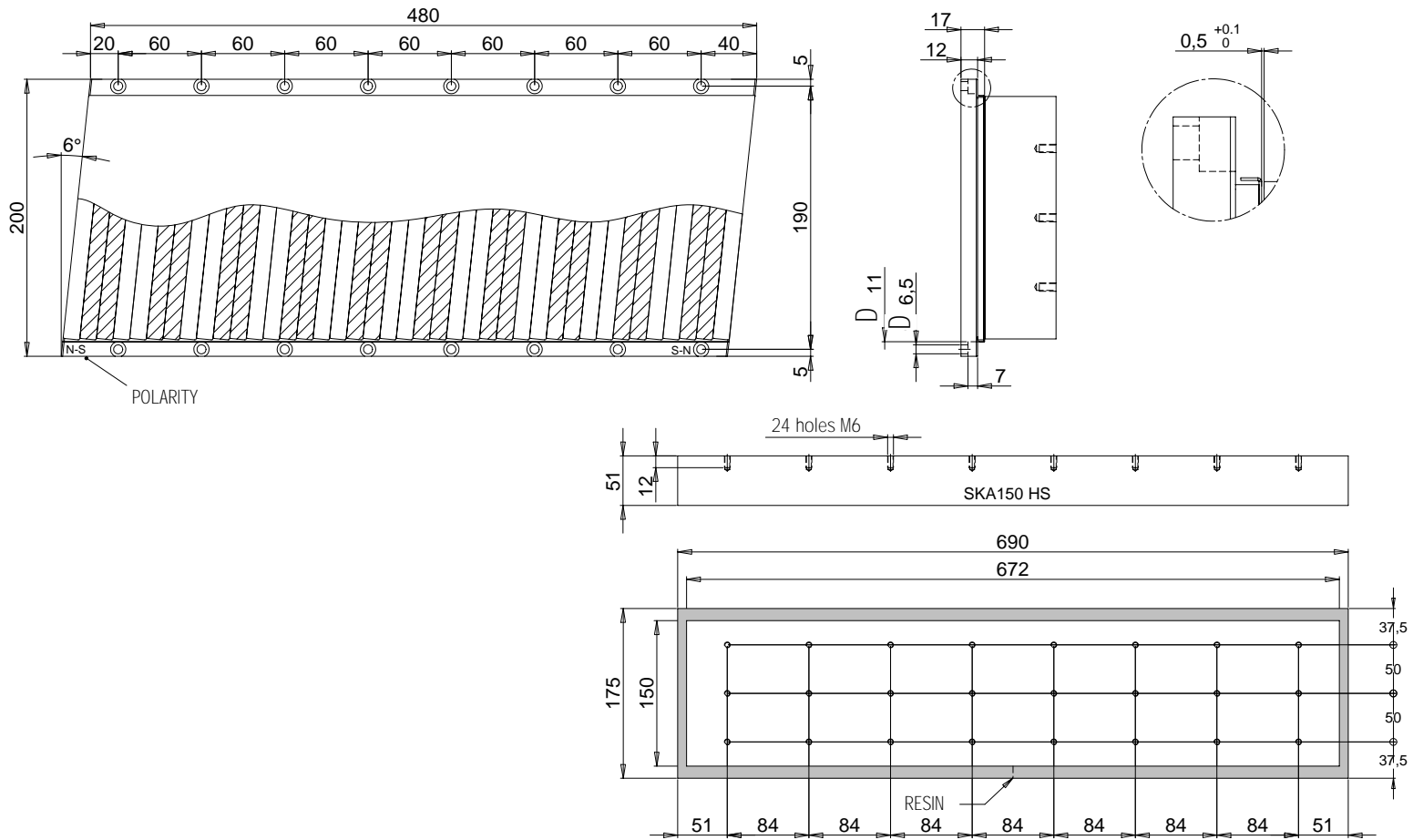

series
SKA 150 HS *Power Parts*

MECHANICAL DATA		HS 2400	
Coil length	L	[mm]	690
Coil width	C	[mm]	175
Coil height	B	[mm]	51
Coil weight		[Kg]	37
Magnet track width	A	[mm]	200
Magnet track height	D	[mm]	17
Magnet track weight		[kg/m]	23
Attraction force		[N]	11790
Coil/magnets alignment		[mm]	± 0.3
Connections	U = White - V = Black - W = Red Thermal prot. = Green		

