

*Capping machine*

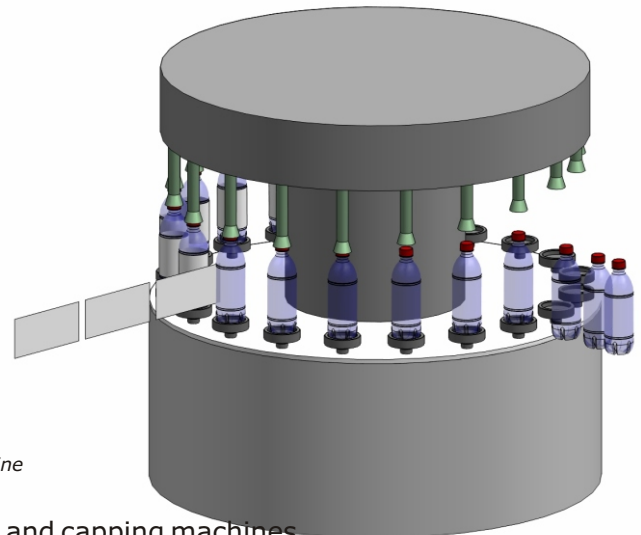

*Labelling machine*

### The need

Rotary carousels are commonly used in labelling and capping machines.

In these systems, it is usually the rotation of the carousel itself that imparts, via a mechanical cam, rotary motion to the bottle holder platter or capping chuck which, in turn, regulate the tightening torque applied with a magnetic clutch. The main shortcomings of a mechanical cam system include reduced efficiency, due to the mechanical couplings which require complex and costly installation procedures and constant maintenance, noisy operation, inadequate or no format flexibility and limited scalability of the machine, both during the design stage of the installation and with a machine already in service.

Recent technological advances in this type of machine on a global scale have led to the replacement of the mechanical cam with an electronic cam. As a result, each platter or chuck is driven by an on-board electric motor. The motor is coupled to the relative utility via belts, pulleys or gear trains to achieve the required reduction ratio, and communicates with a separate machine control system, which manages the operation of all axes. The data traffic generated in this case requires the use of a fast communication bus.

The use of an electronic cam offers advantages in terms of format flexibility, as the format is managed electronically, and allows modifications to the machine operating cycle both during the design stage and with a machine already in service. However, this system still poses a number of disadvantages due to the use of mechanical couplings, such as costly, time consuming installation and maintenance as well as noisy operation.

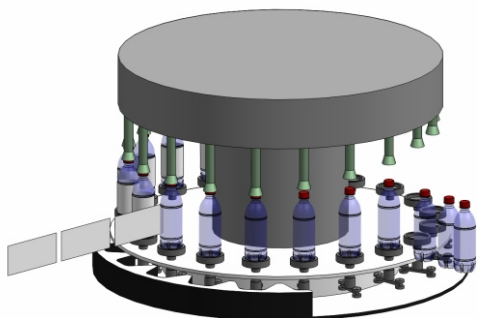

*Mechanical solution*

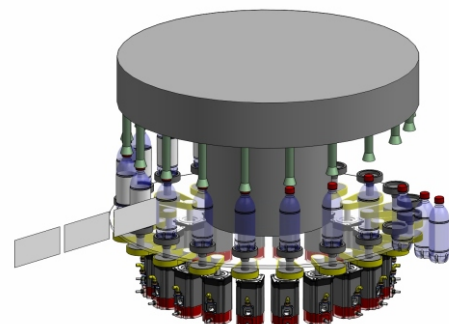

*Electronic solution*

## The solution

The solution proposed by Motor Power Company uses Direct Drive technology in a mechatronic approach, in which the mechanical and electronic components of the machine are developed together right from the start of the design project.

Drive is provided by a 14-pole SKA DDR torque motor with integrated drive, capable of delivering an effective constant torque of 2 Nm and a peak torque of 9 Nm at speeds of up to 1700 rpm.

The integrated Elmo Motion Control intelligent digital drive system (Harmonica series) delivers 4.7 Amps RMS and a peak of 13 Amps at 180 V DC and features a number of digital inputs and outputs, including one Fast Capture. This mechatronic solution offers a number of advantages, primarily attributable to the fact that the motor is mounted directly onto the utility, thus requiring no mechanical transmission. This equates to significant time savings for installation, reduced maintenance, reduced indirect costs for installation and maintenance, zero mechanical imprecision, and extremely quiet operation. However, coupling the torque motor directly to its respective utility exposes the motor to more severe operating conditions: this is why Motor Power Company equips each motor with special bearings to resist the axial and radial loads the motor sustains, while ensuring a protection rating of IP65 for the motor even when installed vertically with the drive shaft pointing upwards. This protection rating means that the motor can be safely washed with water, which is often necessary in these applications. The motor is powered by a DC supply via a single connection cable (power and control logic), whereas communication, which also enables modification to the electronic cam profile, is via CANopen field bus, with a CAN In and a CAN Out connector on board the motor itself, offering a further, significant advantage in terms of simplified wiring with the motor already installed on the carousel.

The intelligent and fully programmable drive significantly reduces the data traffic load on the CAN network. This also contributes to ensuring the same performance in terms of speed and precision, independently of the number of motors installed on the carousel and requiring no fast bus for communication with a separate controller.

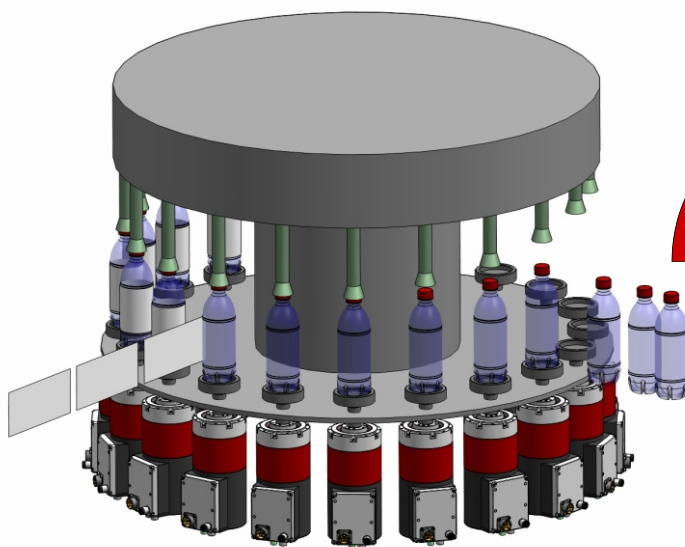

*Solution with Direct Drive technology*

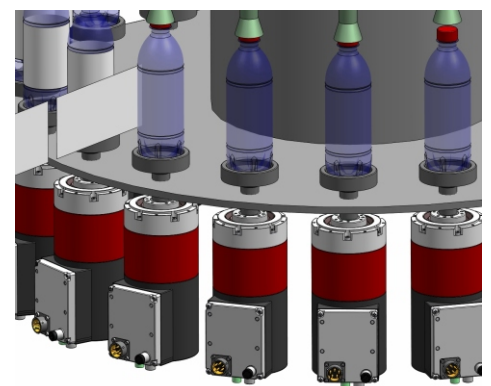

*Detail of the application*

### Advantages

Electronic aspects:

- extreme format flexibility with electronic format management
- machine scalability, both during the design stage and with the machine already in service
- uncluttered connections with simple, easily installed wiring
- digital I/Os available on board motor itself
- completely programmable drive with specific PID also offering control over Direct Drive motors
- application efficiency unaffected by number of motors installed on carousel
- comprehensive range of parameter monitoring and diagnostic functions made possible by the internal functions of the drivers and by the advanced CANopen network between drivers, controller boards and HMIs.

Mechanical aspects:

- no mechanical drive components whatsoever
- quick and simple installation
- zero maintenance
- reduced indirect costs
- high protection ratings available for motors for particularly demanding applications
- incredibly quiet operation

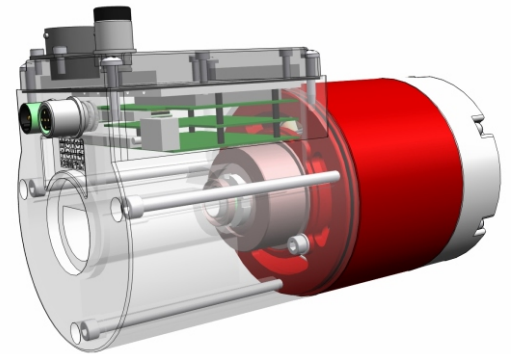

SKA DDR with integrated drive

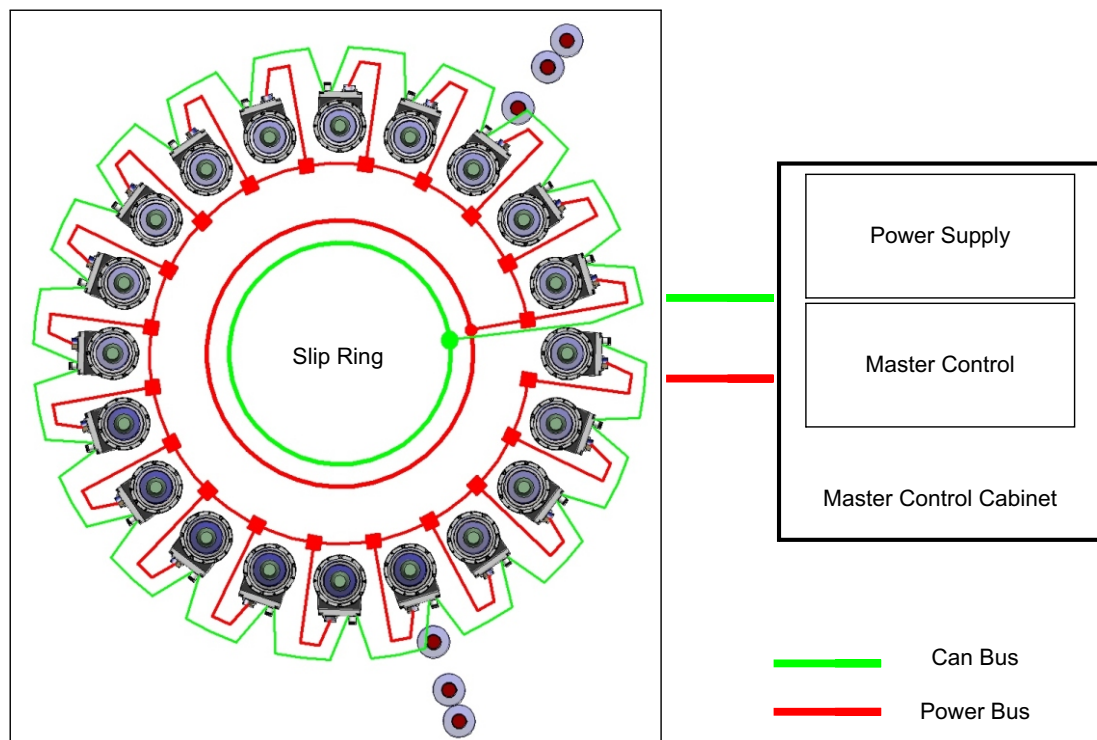

Application architecture