

Dimensions are the same with build-in brake

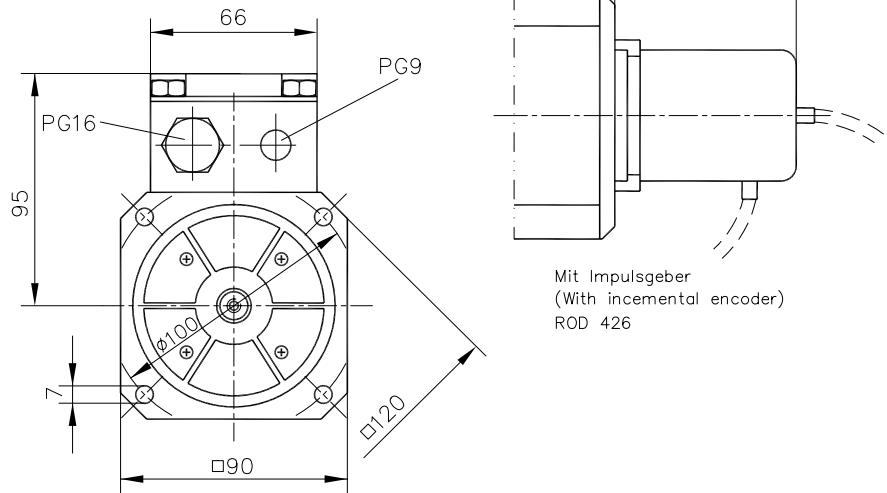

Motor-type	Dimensions					Specifications (extract)							
	k	q	q1	k1	k2	M_0	M_n	I_{0rms}	K_{Trms}	K_E	U_n	R_{ph-ph}	L_{ph-ph}
	mm	mm	mm	mm	mm	Nm	Nm	A	Nm/A	V/1000min ⁻¹	V	Ω	mH
6SM45S-3000	195	160	175	310	380	0,85	0,8	1,3	0,682	58	540	25,4	54
6SM45M-3000	220	185	200	260	330	1,7	1,6	1,3	1,361	116	540	34	99
6SM45L-3000	270	235	250	235	305	3,2	2,9	2,4	1,361	116	540	11,9	47