

Dimensions are the same with build-in brake

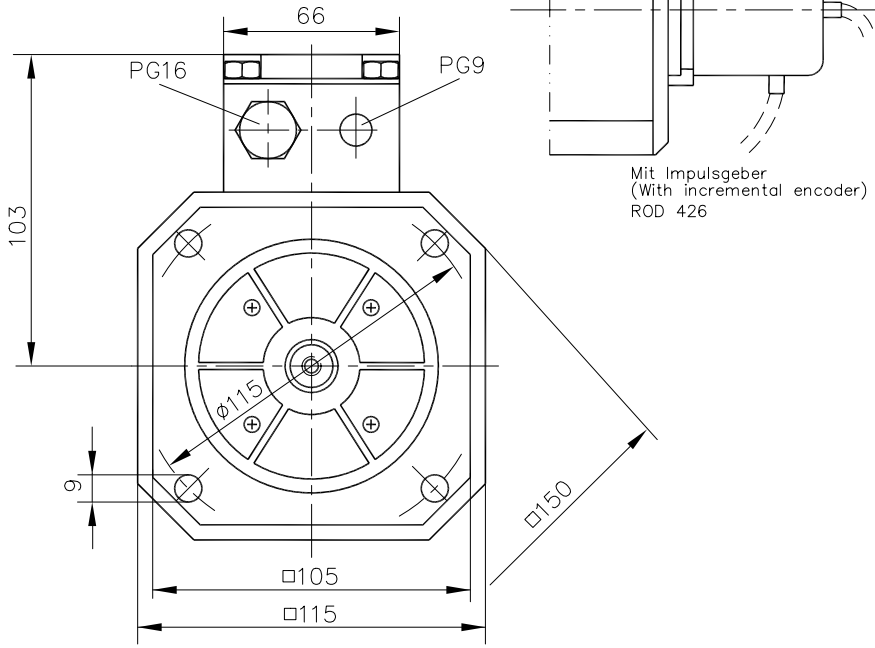

Motor type	Dimensions					Specifications (extract)							
	k	q	q1	k1	k2	M ₀	M _n	I _{0rms}	K _{Trms}	K _E	U _n	R _{ph-ph}	L _{ph-ph}
	mm	mm	mm	mm	mm	Nm	Nm	A	Nm/A	V/1000min ⁻¹	V	Ω	mH
6SM56S-3000	255	212	229	297	365	3,8	3,6	2,8	1,333	114	540	9,4	54,0
6SM56M-3000	295	252	269	337	405	7,0	6,4	4,8	1,450	124	540	4,0	30,0
6SM56L-3000	335	292	309	377	445	10	8,4	7,6	1,322	113	540	1,8	15,8