

# EcoController GEL 8140 - Synchronization Control



07/98

# General information

## Function description

The EcoController GEL 8140 is based on the positioning Controller GEL 8110, i.e. it has the same characteristics and functions. Consequently, the information supplied in the data sheet of the EcoController GEL 8110 applies to the GEL 8140 too.

When using the synchronization control all drives can be freely configured as master or slave drives. With three EcoControllers GEL 8140 one master drive and five slave drives can be controlled analogously. A master drive can be controlled or regulated either by the Controller or by separate devices.

The nominal values for the slave drives are set proportionally or in absolute path differences per sentence, so that programmes with different synchronism or path differences can be created and run.

Upon entering the nominal values a distinction can be made whether the slave drives should be controlled relatively or absolutely to the position of the master drive upon start. Furthermore, the current nominal value can be changed in automatic mode via two trimming inputs.

## Control principle

A newly calculated nominal value for the position is cyclically preset for the drive. The position (s) preset for the slave drive- and consequently the curve of displacement- depends on whether an absolute or proportional synchronism was preset. Therefore the current positions of master and slave axes are stored at the time of start and are taken into account accordingly.

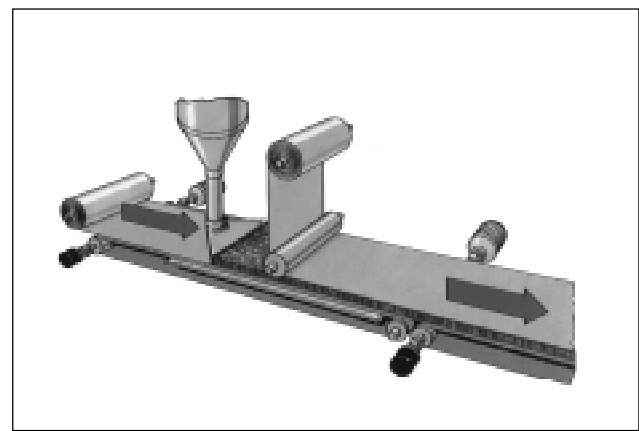
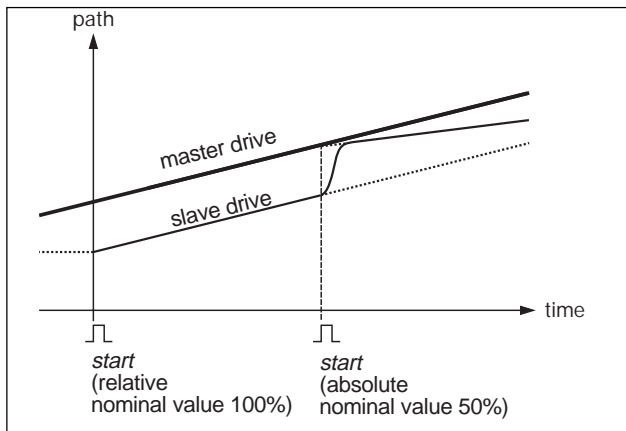
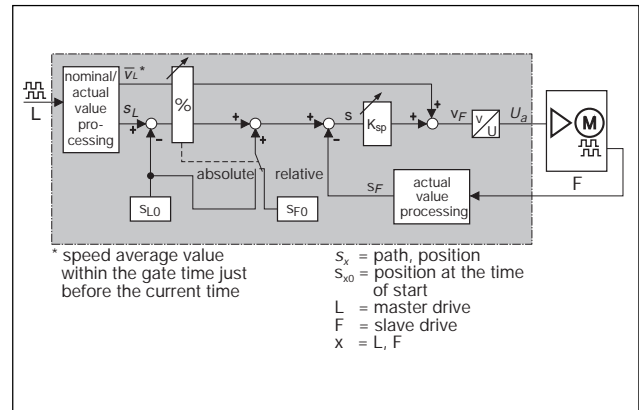

▲ Example for application: plasterboard manufacturing

# Pin layout

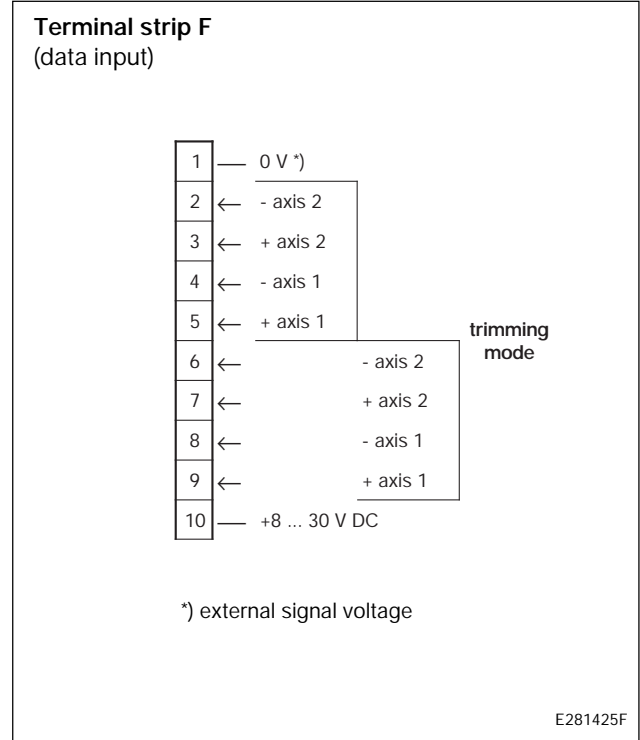
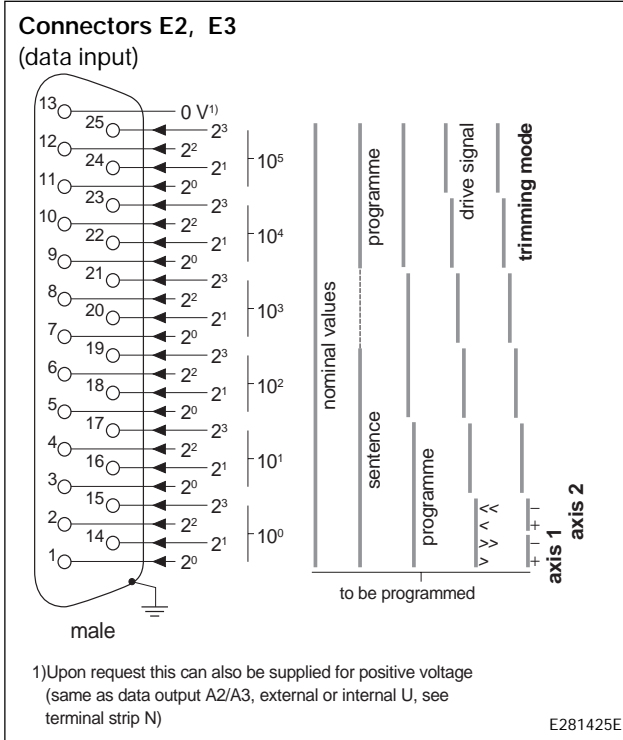
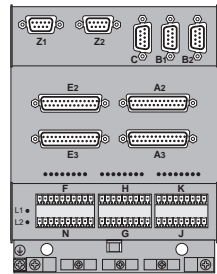

**Note:**

The pin layout is different from the one of the standard version GEL 8110. The divergences are **printed in bold**. For all other pin layouts please refer to the GEL 8110 data sheet.



Lenord, Bauer & Co. GmbH  
Dohlenstraße 32  
46145 Oberhausen, Germany  
Phone +49-208-99 63-0, Fax +49-2 08- 67 62 92  
E-Mail: [info@lenord.de](mailto:info@lenord.de)  
Internet: <http://www.lenord.de>