

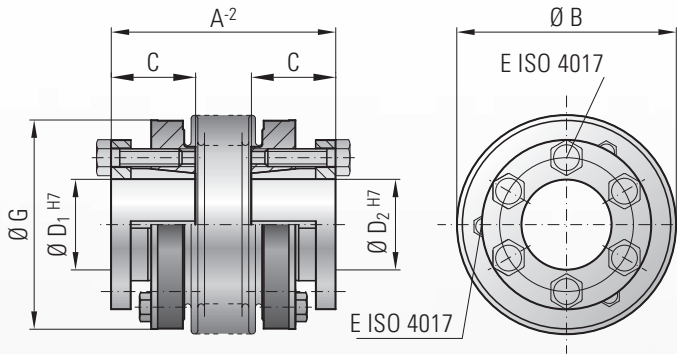

MODEL BK3

TECHNICAL SPECIFICATIONS



Ordering example

BK3 / 60 / 76 / 20 / 22 / XX

Model
Series / Nm
Overall length
Ø D1 H7
Ø D2 H7
Non standard e.g. stainless steel

Properties:

- high clamping forces
- high degree of operating dependability
- new draw off device suited for space restricted installations

Material:

Bellows made of highly flexible high-grade stainless steel, the hub material is steel.

Design:

With tapered conical sleeves and strong, captive ISO 4017 draw-off screws.

Temperature range:

-30 to +120° C (3.6 F - 270 F)

Speeds:

Up to 10,000 rpm, in excess of 10,000 with a finely balanced version.

Service life:

These couplings are maintenance-free if the technical limits are not exceeded.

Backlash:

Absolutely backlash-free due to frictional clamped connection.

Brief overloads:

Acceptable up to 1.5 times the value specified.

Tolerance:

On the hub/shaft connection 0.01 to 0.05 mm

Non-standard application:

Custom designs with varied tolerances, keyways, non-standard material and bellows are available upon request.

Model BK 3		Series											
		15	30	60	150	200	300	500	800	1500	4000	6000	10000
Rated torque (Nm)	T _{KN}	15	30	60	150	200	300	500	800	1500	4000	6000	10000
Overall length (mm)	A	48 55	57 65	66 76	75 87	78 90	89 103	97 110	114	141	195	210	217
Outer diameter of bellows (mm)	B	49	55	66	81	90	110	123	133	157	200	253	303
Fit length (mm)	C	19	22	27	32	32	41	41	50	61	80	85	92
Inner diameter from Ø to Ø H7 (mm)	D	10-22	12-23	12-29	15-38	15-44	24-56	24-60	30-60	35-70	50-100	60-140	70-180
Fastening screws 6x	E	M4	M5	M5	M6	M6	M8	M8	M10	M12	M16	M16	8xM16
Tightening torque of the fastening screws (Nm)		4	6	8	12	14	18	25	40	70	120	150	160
ISO 4017 draw-off screw 3x	F	M4	M4	M5	M5	M6	M6	M6	M6	M8	M10	M10	4xM10
Outer diameter of hub (mm)	G	49	55	66	81	90	110	122	116	145	175	246	295
Moment of inertia (10 ⁻³ kgm ²)	J _{total}	0.12 0.59	0.3 0.34	0.54 0.73	1.2 1.6	1.7 2.5	2.95 5.8	9.1 9.9	13.2	34.9	85.5	254	629
Approx. weight (kg)		0.25	0.4	0.8	1.2	1.8	3	4.2	5.6	8.2	23	32.6	45.5
Torsional stiffness (10 ³ Nm/rad)	C _T	20 15	39 28	76 55	175 110	191 140	450 350	510 500	780	1304	3400	5700	10950
axial (mm)	Max. values	1 2	1 2	1.5 2	2 3	2 3	2.5 3.5	2.5 3.5	3.5	3.5	3.5	3	3
lateral (mm)		0.15 0.2	0.2 0.25	0.2 0.25	0.2 0.25	0.25 0.3	0.25 0.3	0.3 0.35	0.35	0.35	0.4	0.4	0.4
axial spring stiffness (N/mm)	C _a	25 15	50 30	72 48	82 52	90 60	105 71	70 48	100	320	565	1030	985
lateral spring stiffness (N/mm)	C _r	475 137	900 270	1200 420	1500 435	2040 610	3750 1050	2500 840	2000	3600	6070	19200	21800

(1Nm ≅ 8.85 in lbs) max. angular misalignment see BK 1