

optional  
stainless  
steel

# MODEL EK4

## TECHNICAL SPECIFICATIONS

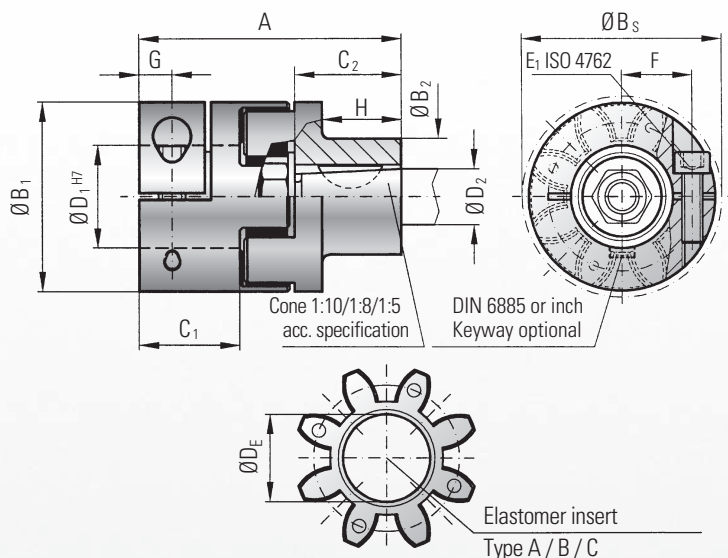

### Properties:

- for conical shaft ends
- short compact design
- easy assembly
- high concentricity
- backlash-free
- electrically insulating

### Material:

Clamping hubs: high strength aluminum  
Conical hub: steel  
Elastomer insert: precision molded, wear resistant, and thermally stable polymer

### Design:

Two coupling hubs are concentrically machined with concave driving jaws  
One side with clamping hub and a radial screw ISO 4762  
One side with a hub conically bored with keyway according to customer requirement

### Speed:

Over 10.000 rpm a finely balanced version is available

### Tolerance:

On the hub/shaft connection 0,01 to 0,05 mm

Model EK 4	Series									
	20			60			150			
Type (Elastomer insert)		A	B	C	A	B	C	A	B	C
Rated torque (Nm)	$T_{KN}$	17	21	6	60	75	20	160	200	42
Max. torque* (Nm)	$T_{Kmax}$	34	42	12	120	150	35	320	400	85
Overall length (mm)	A	57			77			84		
Outer diameter hub (mm)	$B_1$	42			56			66,5		
Outer diameter conical hub (mm)	$B_2$	20			28			30		
Outer diameter with screwhead (mm)	$B_3$	44,5			57			68		
Mounting length (mm)	$C_1$	25			30			35		
Mounting length (mm)	$C_2$	16			29			29		
Inner diameter range H7 (mm)	$D_1$	8-25			12-32			19-35		
Possible conical diameter (mm)	$D_2$	Acc. to customer requirement								
Inner diameter max (elastomer) (mm)	$D_E$	19,2			27,2			30,2		
Mounting screw (ISO 4762/12.9)		M5			M6			M8		
Tightening torque of the mounting screw (Nm)	$E_1$	8			15			35		
Distance between centers (mm)	F	15,5			21			24		
Distance (mm)	G	8,5			10			12		
Length (mm)	H	9,5			21			19		

Information about static and dynamic torsional stiffness as well as max. possible misalignment see page 4

1 Nm = 8,85 in lbs

\*\* Maximum transferable torque of the clamping hub depends on the bore diameters (bore/shaft clearance 0,01 mm to 0,05 mm shaft oiled)

Series	Ø 8	Ø 16	Ø 19	Ø 25	Ø 30	Ø 32	Ø 35
20	20	35	45	60			
60		50	80	100	110	120	
150			120	160	180	200	220

Higher torque through additional key possible.

### Ordering example

EK4 / 20 / A / 24 / 1:10 Ø11 / XX

Model  
Series  
Type Elastomer insert  
Bore Ø D1 H7  
Cone/ Ø D2  
Non standard e.g. finely balanced

All data is subject to change without notice.

### Installation instruction

**Mounting of the clamping hub:** Slide the coupling on the shaft ends, at the right axial position tighten the mounting screw to the specified tightening torque as shown in the table ( column E1).

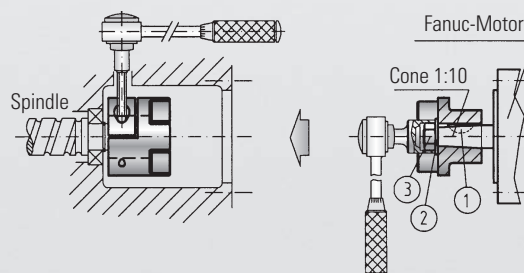

**Mounting of the conical hub:** After inserting the key into the keyway of the motor shaft slide the coupling hub on the shaft. Check if the conical hub has a proper seat on the shaft. Now the nut (3) can be tightened on the motor shaft using the exact tightening torque specified by the motor manufacturer.