

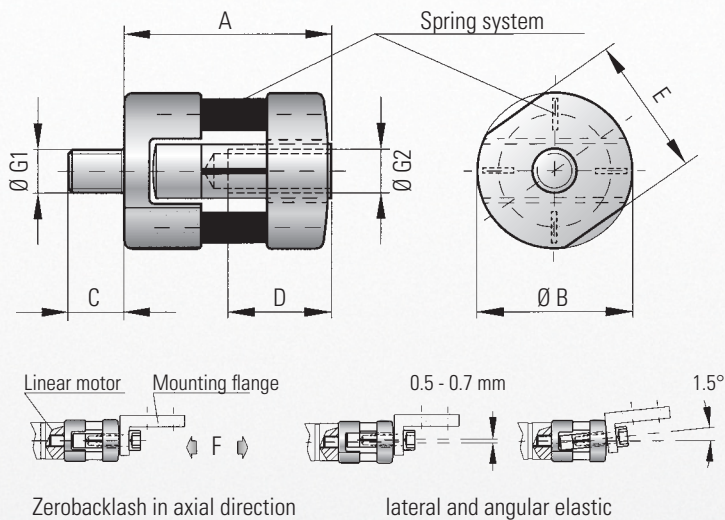

MODEL LK

LINEAR COUPLINGS



Ordering specifications

LK / 70 / XX

Model
Series/Nominal tensile force*
Special e.g. VA-Design

Model LK		Series					
		70	150	300	500	800	2000
Pressure force (N)	F	70	150	300	500	800	2000
Overall length (mm)	A	24	33	41.5	52	62	93
Outer diameter (mm)	B	18	22	30	42	50	72
Outer diameter of thread (mm)	G _{1/2}	M5	M6	M8	M10	M12	M16
Max. tightening torque thread (Nm)		4	7	18	30	60	170
Thread length (mm)	C	6.5	8	10	13	18	24
Thread length (mm)	D	10	12	16	20	24	32
Key width (mm)	E	16	20	27	38	46	60
Weight approx. (g)		11	23	57	135	236	580
Lateral restoring force (N)	max. values	10	18	48	96	122	180
lateral (mm)		0.5	0.5	0.5	0.7	0.7	0.7
angular (Grad)		1.5	1.5	1.5	1.5	1.5	1.5

Properties:

- Zero backlash in axial direction
- compensates angular misalignments up to 1.5° and lateral misalignments up to 0.7 mm (0,028 inch)
- low mass & weight = low inertia
- compact design
- designed for high tensile and compressive forces in highly dynamic applications

Material:

Coupling components are made of high-strength aluminium. Spring elements are made of special spring steel

Structure:

Input side: internal metric thread
Output side: external metric thread
The connection between the input and output side of the coupling is via two sets of backlash free leaf-spring systems.

Temperature range:

-30 to + 120° C (3.6 F to 270 F)

Backlash:

absolutely backlash-free

Brief overloads:

Acceptable up to 1.5 times the rated value

Service life:

These couplings have an infinite life and are maintenance free if operated within performance limits.

Special Design:

Custom bores, threads, and material available upon request.

Mounting Instructions

- Mounting: "Wrench flats" have been machined into the coupling hubs to aid in the mounting and dismounting of the coupling.
- **Caution: Do not exceed the tightening torque during mounting (see table)!**
- While mounting, ensure not to damage leaf-spring system
- **Maximum lateral and angular misalignment value must not be exceeded.**

The information mentioned in this document is based on our present knowledge and experiences and does not exclude the manufacturer's own substantial testing of the equipment. So this is no obligatory assurance even with regard to protection rights of Third Parties. The sale of our products is subject to our General Conditions of Sale and Delivery.

350/10/04/3.000