

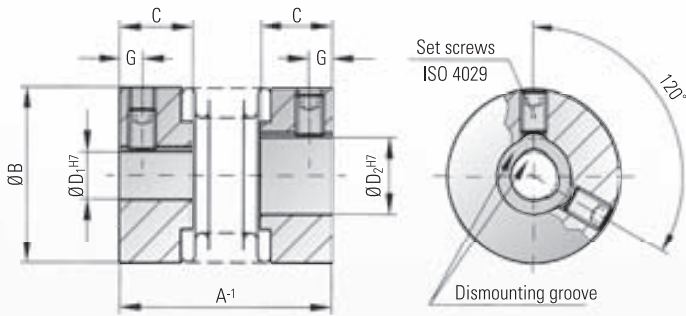

# MODEL MK1

## TECHNICAL SPECIFICATIONS



common solutions:



### Ordering example

MK1 / 5 / 26 / 4 / 5 / XX

Model  
Series/Nm  
Overall length  
Ø D1 H7  
Ø D2 H7  
Non standard

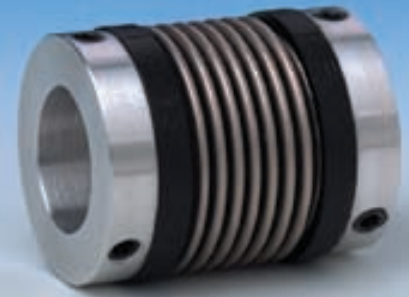

### Properties:

- backlash-free and torsionally rigid
- low-cost design
- low moment of inertia
- compensates for 3-axis of misalignment
- a mounting groove or flattening of the shaft is not required due to the integrated dismounting groove

### Material:

Bellows are made of highly flexible high-grade stainless steel, hubs from aluminium.

### Design:

Hubs with DIN 916 radial set screw and **integral dismounting groove**.

### Temperature range:

-30 to +120° C (3.6 F to 270),

### Speeds:

Up to 20,000 rpm, in excess of 20,000 rpm with balanced version

### Service life:

These coupling have an infinite service life, and are maintenance free, if the technical limits are not exceeded.

### Fit tolerance:

On the hub/shaft connection 0.01 to 0.08 mm.

### Non-standard application:

Custom designs with varied tolerances, keyways, non-standard material and bellows are available upon request.

Model MK 1		Series																	
		0.5		1		5			10			15		20		45		100	
Rated torque (Nm)	T <sub>KN</sub>	0.05		0.1		0.5			1.0			1.5		2.0		4.5		10	
Overall length (mm)	A	14	20	20	23	26	22	25	28	24	29	26	31	35	37	45	43	53	
Outer diameter (mm)	B	6.5		10		15			15			19		25		32		40	
Fit length of hub (mm)	C	4		5		6.5			6.5			7.5		11		13		15	
Special bores from Ø to Ø (mm)	D <sub>1/2</sub>	1-3		1-5		3-9			3-9			3-12		3-16		6-22		6-28	
Standard bore H7 (mm)	D <sub>1/2</sub>	2		3		6			6			6/10		6/10		10		10	
Clamping screw ISO 4029	E	1xM2		1xM2.5		1xM3			1xM3			2xM3		2xM4		2xM5		2xM6	
Tightening torque of the assembly screws (Nm)		0.35		0.75		1.3			1.3			1.3		2.5		4		6	
Distance (mm)	G	1.5		1.8		2			2			2		2.5		3.5		4	
Mass moment of inertia (gcm <sup>2</sup> )	J	0.1	0.4	1.1	1.2	1.3	1.3	1.8	2	4.7	5.5	15	18	20	65	70	180	220	
Weight (g)		1	5	6	6	6	6	7	8	12	14	22	24	26	54	58	106	114	
Torsional stiffness (Nm/rad)	C <sub>T</sub>	50		70		280			210			170		510		380		320	
axial  (mm)	Max. values	0.4		0.4		0.4			0.5			0.6		0.4		0.5		0.6	
lateral  (mm)		0.1		0.15		0.15			0.2			0.15		0.2		0.15		0.25	
angular  (degrees)		1		1		1			1.5			2		1		1.5		2	

Integral dismounting groove from bore diameter 4 mm and larger. (1 Nm = 8.85 in lbs)