

optional
stainless
steel

MODEL MK2

TECHNICAL SPECIFICATIONS

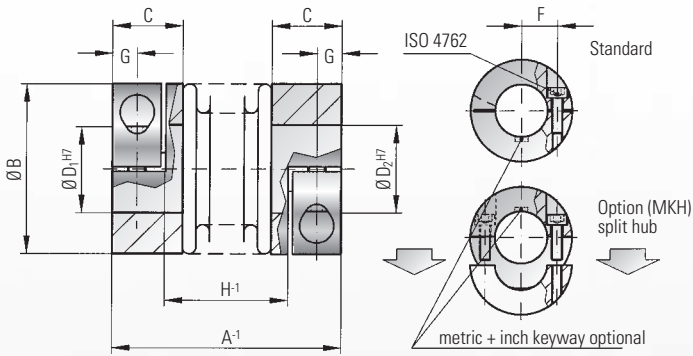

Ordering example

MK2 / 5 / 25 / 4 / 5 / XX

Model
Series/Nm
Overall length
Ø D1 H7
Ø D2 H7
Non standard

MKH = split hub



Properties:

- frictional connection utilizing clamping hubs
- for high dynamic applications
- backlash-free and torsionally rigid
- low moment of inertia
- compensates for 3-axis of misalignment

Material:

Bellows are made of highly flexible high-grade stainless steel, hubs from aluminium.

Design:

Standard: With a single radial clamping screw per hub ISO 4762

Option (MKH): Both clamping hubs completely removable

Temperature range:

-30°C to +120°C (3,6 F to 270 F)

Speeds:

Up to 10,000 rpm, in excess of 10,000 rpm with balanced version.

Service life:

These couplings have an infinite life, and are maintenance-free if the technical limits are not exceeded.

Fit tolerance:

On the hub/shaft connection 0.01 to 0.05 mm.

Non-standard application:

Custom designs with varied tolerances, keyways, non-standard material and bellows are available upon request.

Model MK 2		Series														
		5			10			15		20			45		100	
Rated torque (Nm)	T_{KN}	0.5			1.0			1.5		2.0			4.5		10	
Overall length (mm)	A	25	28	31	27	30	33	30	35	35	40	44	46	54	50	60
Outer diameter (mm)	B	15			15			19		25			32		40	
Fit length of hub (mm)	C	9			9			11		13			16		16	
Special bores from Ø to Ø (mm)	$D_{1/2}$	3-7			3-7			3-8		3-12.7			5-16		5-24	
Standard bore H7 (mm)	$D_{1/2}$	6			6			6		6/10			10		10	
Screws DIN 912		M2			M2			M2.5		M3			M4		M4	
Tightening torque of the assembly screws (Nm)	E	0.43			0.43			0.85		2.3			3.5		4.5	
Distance between centers (mm)	F	4.5			4.5			6		8			10		15	
Distance (mm)	G	3			3			3.5		4			5		5	
(H)	H	12	15	18	14	17	20	14.5	19.5	17	22	26	23.5	31.5	27.5	37.5
Mass moment of inertia (gcm ²)	J_{ges}	2.6	2.8	3	3	3.4	3.6	8.5	9.5	25	27	29	100	108	160	205
Weight (g)		9	9	9	9	10	11	22	24	36	38	40	74	78	120	130
Torsional stiffness (Nm/rad)	C_T	280	210	170	510	380	320	750	700	1200	1300	1200	7000	5000	9050	8800
axial (mm)	Max. values	0.4	0.5	0.6	0.4	0.5	0.6	0.5	0.7	0.5	0.6	0.7	0.7	1	1	1.2
lateral (mm)		0.15	0.2	0.25	0.15	0.2	0.25	0.15	0.2	0.15	0.2	0.25	0.2	0.25	0.2	0.3
angular (degrees)		1	1.5	2	1	1.5	2	1.5	1.5	1.5	1.5	2	1.5	2	1.5	2

1 Nm = 8,85 in lbs