

optional
stainless
steel

MODEL MK4

TECHNICAL SPECIFICATIONS

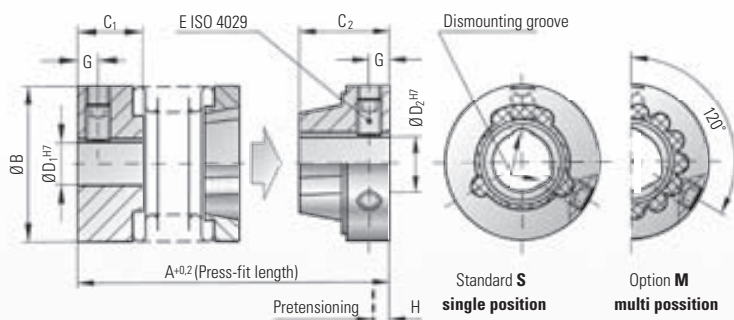

Ordering example

MK4/20 / 37 / 8 / 10 / XX

Model
Series/Nm
Overall length
Ø D1 H7
Ø D2 H7
Non standard e.g. Option M

Properties:

- electrically insulated
- no wear
- easy mounting and dismounting
- absolutely backlash-free and torsionally rigid
- low moment of inertia
- compensates for 3-axis of misalignment

Material:

Bellows made of highly flexible high-grade stainless steel; clamping hubs and tapered segment on bellows face from aluminium. Tapered segment on the hub face: glass-fiber reinforced plastic sprayed onto an aluminium hub.

Design:

Both hubs have radial set screws and integral dismounting grooves. One hub incorporates a blind mate press-fit connection.

Temperature range:

-30° to +120°C (3,6 F to 270 F)

Speeds:

Up to 20,000 rpm, in excess of 20,000 rpm with balanced version

Service life:

These couplings have an infinite life, and are maintenance-free if the technical limits are not exceeded.

Fit tolerance:

On the hub/shaft connection 0.01 to 0.08 mm.

Non-standard application:

Custom designs with varied tolerances, keyways, non-standard material and bellows are available upon request.

Model MK 4		Series											
		5			15		20			45		100	
Rated torque (Nm)	T _{KN}	0.5			1.5		2			4.5		10	
Overall length without any pretensioning (mm)	A	22	25	28	26	31	28	33	37	39	47	46	56
Outer diameter (mm)	B	15			19		25			32		40	
Fit length (mm)	C ₁	6.5			7.5		11			13		15	
Fit length (mm)	C ₂	9			10		11			14		16	
Special bores from Ø to Ø (mm)	D ₁	3-9			3-12		3-16			6-22		6-28	
Special bores from Ø to Ø (mm)	D ₂	3-6.35			3-9		3-12.7			6-16		6-20	
Standard bore H7 (mm)	D _{1/2}	6			6		6/10			10		10	
Screws ISO 4029		1xM3			2xM3		2xM4			2xM5		2xM6	
Tightening torque of the assembly screws (Nm)	E	1.3			1.3		2.5			4		6	
Pretensioning approx. (mm)	H	0.4			0.5		0.5			0.7		1	
Distance (mm)	G	2			2		2.5			3.5		4	
Axial recovery force of coupling (N)		5	3	2	4	3	3	4	3	15	10	25	30
Mass moment of inertia (gcm ²)	J _{GES}	2.0	2.2	2.5	5.5	6.0	21	23	25	80	85	200	210
Torsional stiffness (Nm/rad)	C _T	280	210	170	750	700	1200	1300	1200	7000	5000	9050	8800
axial (mm)	Max. values	0.4	0.5	0.6	0.5	0.7	0.5	0.6	0.7	0.7	1	1	1.2
lateral (mm)		0.15	0.2	0.25	0.15	0.2	0.15	0.2	0.25	0.2	0.25	0.2	0.3
angular (degrees)		1	1.5	2	1.5	1.5	1.5	1.5	2	1.5	2	1.5	2

Integrated dismounting groove from bore diameter 4 mm and larger. (1 Nm = 8.85 in lbs)