

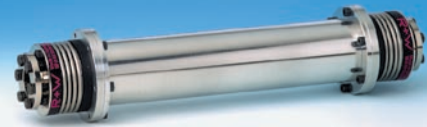

MODEL ZA 1500-4000 Nm

TECHNICAL SPECIFICATIONS

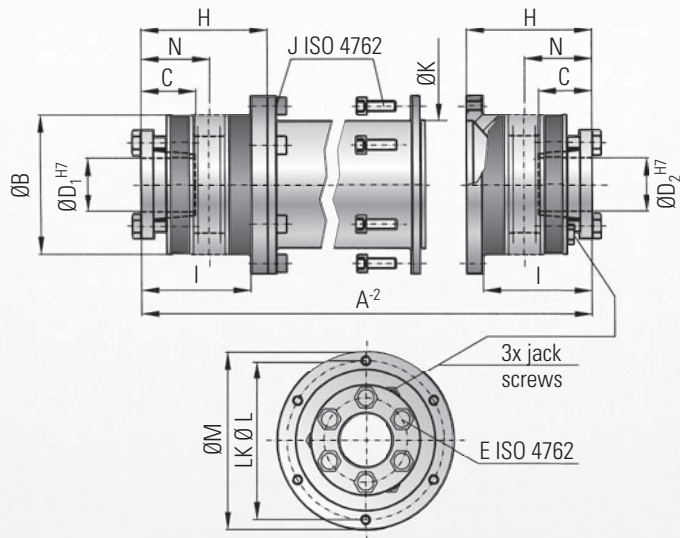

Properties:

- Compensation of misalignments
- Backlash-free and torsionally stiff
- Able to span longer distances
- Standard lengths up to 3 m (9.84 ft)
- No intermediate support bearing required
- Intermediate tube removable for easy mounting

Material:

- Bellows made of flexible high grade stainless steel
- Intermediate tube section: steel, **optional composite CFK tube**
- Clamping hubs: steel

Design:

- With tapered conical sleeves and captive jack screws
- Intermediate tube section support by gimbals within the clamping hub.
- Lateral mounting and dismounting accomplished due to the removal of the intermediate tube section.

Temperature range:

-30 to +120° C (-22 to 250° F)

Speed:

Depending on length A, please contact R+W

Service life:

These couplings have an infinite life and are maintenance-free if the technical limits are not exceeded

Backlash:

Absolutely backlash-free due to frictional clamp connection

Fit tolerance:

Shaft/hub connection 0.01 to 0.05 mm

Ordering example

ZA / 1500 / 2551 / 65 / 70 / XX

Model
Series/rated torque
Overall length
 $\varnothing D1 H7$
 $\varnothing D2 H7$
Non-Standard e.g. carbon tube

Model ZA 1500 - 4000 Nm		Series	
		1500	4000
rated torque (Nm)	T_{KN}	1500	4000
Overall length min. to max. (mm)	A^{-2}	240 to 3000	280 to 3000
Outer diameter (mm)	B	157	200
Fit length (mm)	C	61	80,5
Inner diameter from \varnothing to $\varnothing H7$ (mm)	$D_{1/2}$	35 to 70	40 to 100
ISO 4017 clamping screws	6x E	M12	M16
Tightening torque (Nm)		70	120
Length bellows body (mm)	H	98	103,5
	I	82	84
ISO 4762 screw		10x M10	12x M12
Tightening torque of the assembly screws (Nm)	J	70	120
Outer diameter tube section (mm)	K	150	160
Bolt hole circle \varnothing (mm)	L	168	193
Outer diameter flange (mm)	M	184	213
Shaft average value (mm)	N	56	61

max. permissible misalignments page 6

Vertical installation ZA/ZE

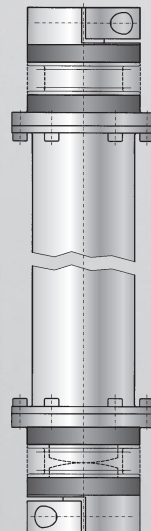

- While vertical mounting an additional supporting of the lower bellows body is necessary.
- A special bellows body for vertical mounting is available upon request.
- Please note „vertical mounting“ when ordering.