

DYNABOX XL

Right angle
Servo gearheads
For heavy duty applications



Backlash down to 0,5 arc minute

Torque up to
8000 Nm



GIRARD TRANSMISSIONS introduces :

DYNABOX XL

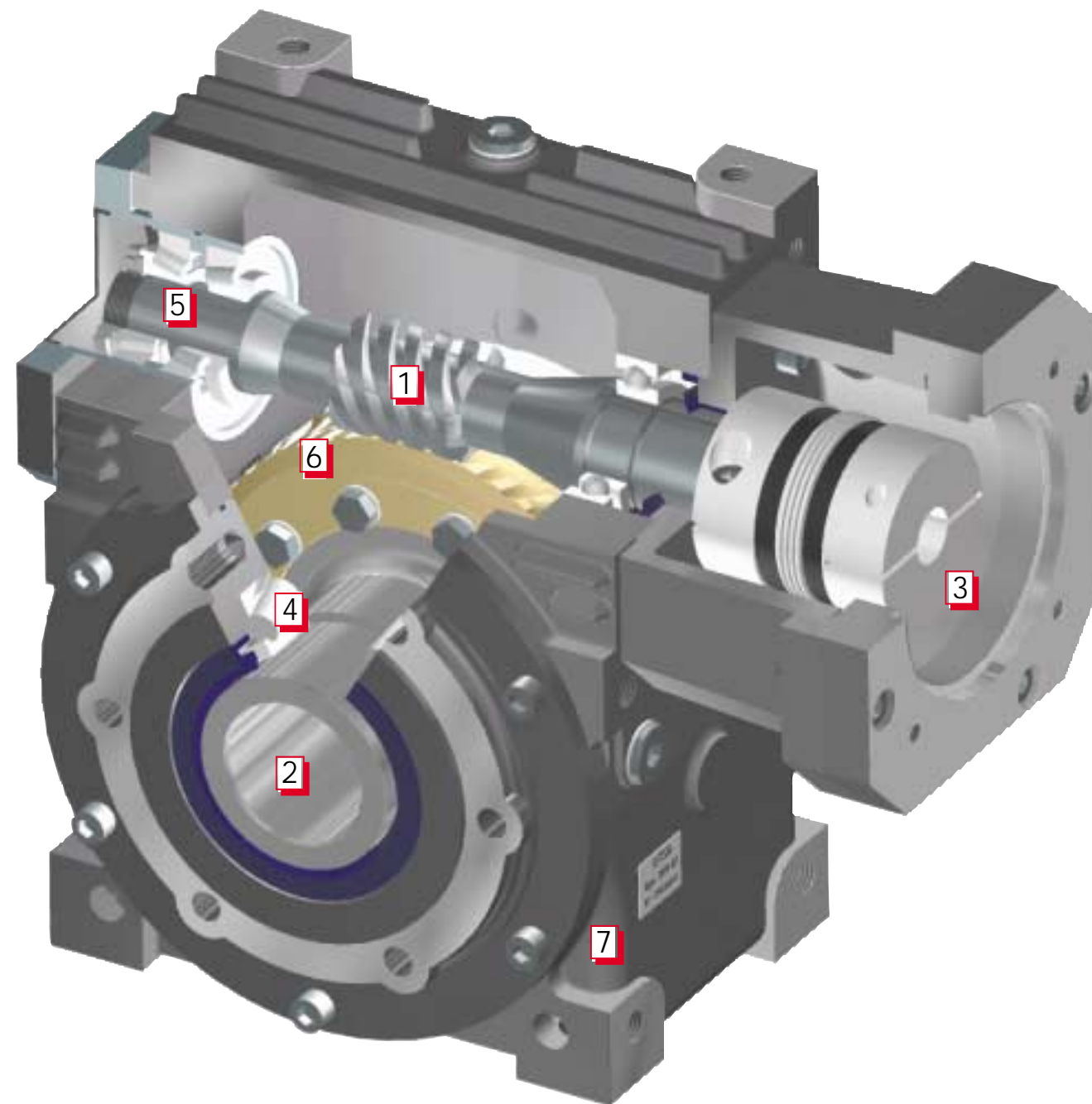

with 2 precision levels :

EXPERT : backlash < 0,5 arcminute
(adjustable)

MEDIUM : backlash < 5 arcminutes
(fixed)

- 1 Computer optimized gear contact pattern : less stress, longer life.
- 2 Keyless connection : reliable and backlash free connection with shrink disc.
- 3 Universal servo-kit : including high torsional stiffness coupling + flange.
- 4 Oversized taper roller bearings : provide very high permissible loads.
- 5 Constant input bearings preload design : 2 taper roller bearings + 1 floating ball bearings allowing temperature variations with same preload : higher input permissible speeds, longer life.
- 6 Centrifugally cast wheel ring : superior shock and wear resistance.
- 7 Cast iron housing

2 MOUNTING OPTIONS



Hollow shaft



Single output shaft

DYNABOX XL benefits

Low backlash

Space saving configuration : the right-angle design, more compact, is favourable in most cases.

Wormgear : very silent, more important permissible overloads, higher torsional stiffness.

Maintenance free : life-lubricated unit with high performances synthetic lubricant.

DYNABOX XL SELECTION

START/STOP SERVICE S5

Calculate torque S5 on gearbox output :

$$\text{Torque S5} = T_{\max} \times F1 \times F2$$

GEARBOX RUNNING TIME DURING 1 CYCLE				
	10 %	30 %	50 %	60 %
F1	0,7	0,85	1	1,15

over 60 %, go to CONTINUOUS SERVICE selection

NUMBER OF CYCLES/HOUR					
	1000	2000	3000	5000	10000
F2	1	1,35	1,45	1,6	1,9

Pre-select the gearbox size :
in the column Torque S5, at N_{max} input speed

CONTINUOUS SERVICE S1

Calculate torque S1 on gearbox output :

$$\text{Torque S1} = T_{\max}$$

Pre-select the gearbox size :
in the column Torque S1, at N_{max} input speed

Calculate the power P_{th} lost during cycle :

n_{1,2,3} : average output speed of each period
T_{1,2,3} : output torque of each period
η_{1,2,3} : average efficiency of each period
(to be calculated from page 5)
t_{1,2,3} : duration of each period

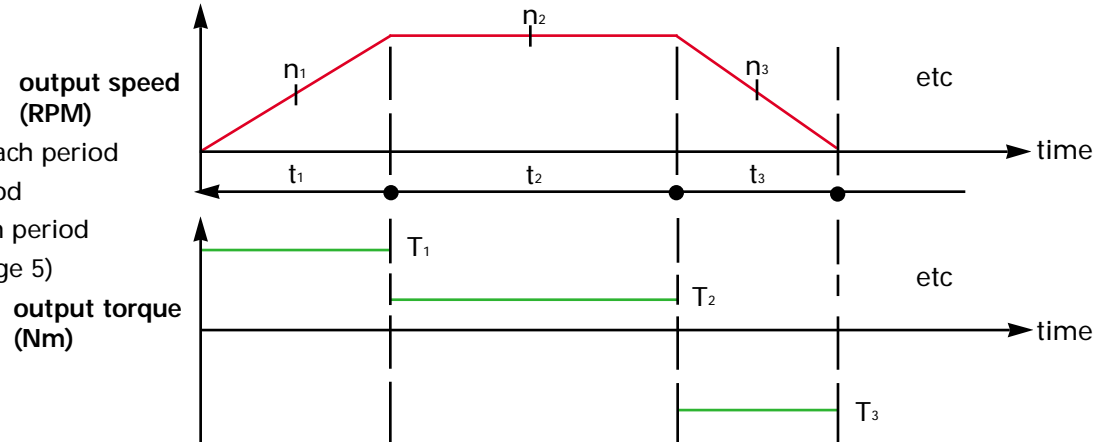

$$P_{th} = 0,105 \times \sqrt[3]{\frac{t_1 \left(\frac{100 - \eta_1}{\eta_1} \times n_1 T_1 \right)^3 + t_2 \left(\frac{100 - \eta_2}{\eta_2} \times n_2 T_2 \right)^3 + t_3 \left(\frac{100 - \eta_3}{\eta_3} \times n_3 T_3 \right)^3 + \dots}{t_1 + t_2 + t_3 + \dots}}$$

P_{th} must be lower than the thermal capacity of the pre-selected gearbox size, otherwise select a larger gearbox.

Thermal capacities :	DYNABOX XL 125	1652W
	DYNABOX XL 160	2479W
	DYNABOX XL 200	4210W

LEGEND

T_{max} (Nm) : maximum output torque during operating cycle / continuous operation.
N_{max} (RPM) : maximum input speed achieved during operating cycle.
E-stop (Nm) : gearbox output emergency torque (2 seconds maximum duration, maximum of 25000 times).
i : exact gear ratio.
ig (kgxcm²) : polar moment of inertia on input, without coupling (see coupling inertia page 10).
η (%) : gearbox efficiency.
Fr (N) : maximum radial load applicable at the middle of the output shaft, without any axial load.
Fa (N) : maximum axial load applicable on output shaft, without any radial load.

TECHNICAL SPECIFICATIONS

N _{max}	i	6000			4000			3000			2000			1000			E-stop	ig	Rever. class	Fr	Fa
		Torque S5	η	Torque S1	Torque S5	η	Torque S1	Torque S5	η	Torque S1	Torque S5	η	Torque S1	Torque S5	η						
DYNABOX XL 125	5,125:1	792	97	609	1005	96	716	1181	96	884	1459	95	1217	2008	94	3767	50	1	13600	12000	
	7,2:1	840	97	632	1043	96	742	1224	95	907	1497	95	1208	1993	93	3767	38	1	15000	15000	
	10,25:1	832	96	622	1026	95	725	1196	95	887	1464	94	1147	1893	92	3767	30,5	1	16700	18000	
	15,25:1	726	94	542	894	93	625	1031	92	759	1252	91	972	1604	89	3342	25	1	18900	22000	
	20,5:1	1026	93	759	1252	92	877	1447	91	1043	1721	89	1320	2178	87	3767	23,4	1	20600	22000	
	29,5:1	869	90	634	1046	88	731	1206	87	861	1421	85	1079	1780	81	3295	23,15	2	22900	22000	
	45:1	1142	86	833	1374	84	952	1571	82	1104	1822	80	1369	2259	75	3767	21	3	26000	22000	
	60:1	980	82	713	1176	79	815	1345	77	929	1533	74	1150	1898	69	2937	20	3	28000	22000	
	90:1	825	74	598	987	71	680	1122	68	779	1285	64	960	1584	58	2502	19	3	32000	22000	

DYNABOX XL 160	5,125:1	1450	97	1128	1861	97	1324	2185	96	1648	2719	96	2334	3851	94	7251	120	1	17800	15000
	7,2:1	1411	97	1092	1802	96	1266	2089	96	1569	2589	95	2151	3549	94	7251	77	1	19700	19000
	10,25:1	1513	96	1161	1916	96	1346	2221	95	1650	2723	94	2215	3655	93	7251	63	1	21900	24000
	15,25:1	1333	95	1030	1700	94	1177	1942	93	1443	2381	92	1896	3128	90	5572	52,7	1	24700	29000
	20,5:1	1775	94	1338	2208	93	1530	2525	92	1856	3062	90	2392	3947	88	7251	51,5	1	27000	34000
	29,5:1	1492	91	1111	1833	89	1264	2086	88	1535	2533	86	1945	3209	83	6571	52,8	2	30000	34000
	45:1	2219	87	1630	2690	85	1858	3066	84	2211	3648	81	2765	4562	77	7251	46,5	3	34100	34000
	60:1	1740	83	1272	2099	81	1439	2374	79	1723	2843	76	2127	3510	71	6331	40	3	37200	34000
	90:1	1552	76	1123	1853	73	1261	2081	70	1489	2457	67	1842	3039	60	4933	38	3	42000	34000

DYNABOX XL 200	5,125:1	2592	98	2008	3313	97	2392	3947	97	2954	4874	96	4208	6943	95	12826	287	1	37000	37500
	7,2:1	2721	97	2108	3478	97	2462	4062	96	3042	5019	96	4236	6989	94	12826	177	1	41000	44500
	10,25:1	2691	97	2071	3417	96	2408	3973	96	2946	4861	95	4007	6612	93	12826	143	1	46000	52600
	15,25:1	2346	95	1813	2991	94	2083	3437	94	2540	4191	93	3376	5570	91	12448	102	1	51800	63000
	20,5:1	3356	94	2551	4209	93	2909	4800	92	3538	5838	91	4590	7574	89	12826	96	1	56600	71000
	29,5:1	2841	92	2117	3493	90	2410	3977	89	2925	4826	87	3738	6168	84	12277	99	2	63000	71000
	45:1	3747	88	2775	4579	86	3154	5204	85	3788	6250	83	4747	7833	78	12826	82,5	3	71700	71000
	60:1	3170	85	2325	3836	82	2636	4349	80	3159	5212	77	3928	6481	72	11674	71	3	78000	71000
	90:1	2714	78	1985	3275	75	2228	3676	72	2641	4358	69	3316	5471	62	9323	69	3	88000	71000

REVERSIBILITY CLASSES

Reversibility means the gearbox capability to be back-driven. When selecting an irreversible gearbox, make sure that

during deceleration, load inertia does not create overloads exceeding the maximum permissible torque.

1	Totally reversible
2	Uncertainly reversible
3	Irreversible

NOTES CONCERNING EFFICIENCY

Efficiency values may be achieved after a minimum of 24 hours at full load operation (running-in-period). Efficiency values are achieved only when gearbox operates at

nominal torque. For gearbox operating under nominal torque, efficiency is lower.

DYNABOX XL HOLLOW SHAFT

SMOOTH SHAFT FOR SHRINK DISC

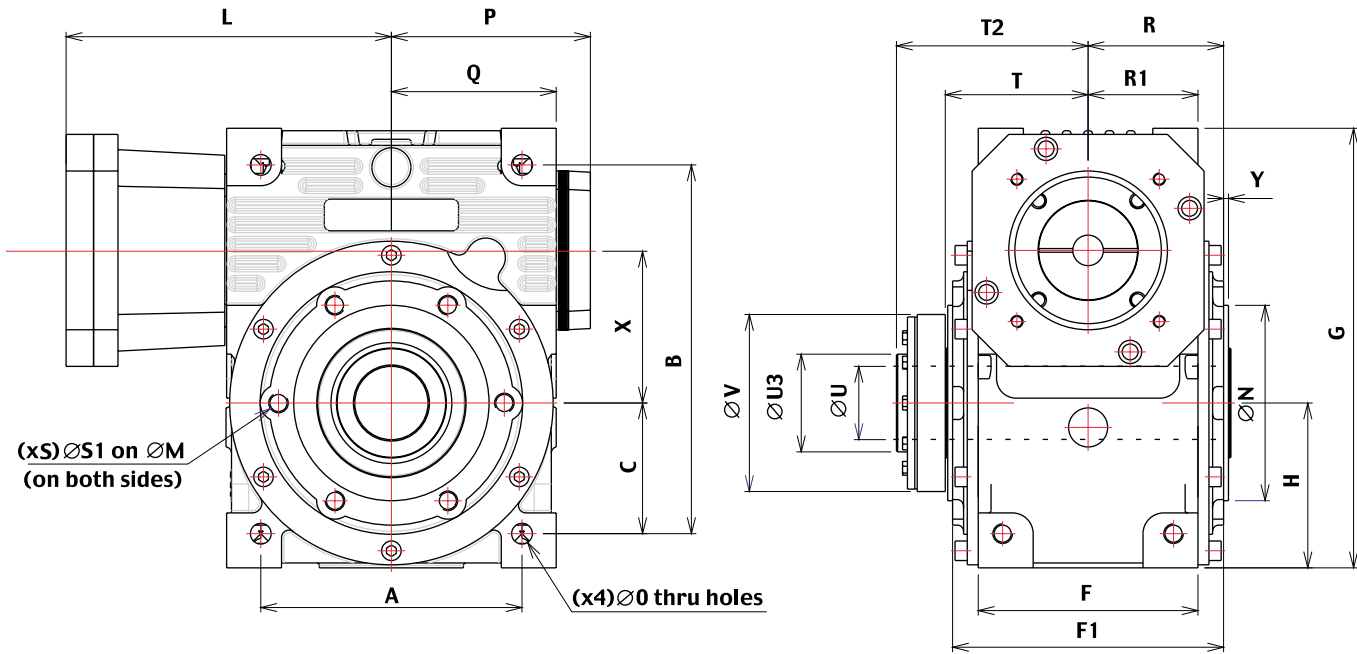

INPUT SHAFT VERSION

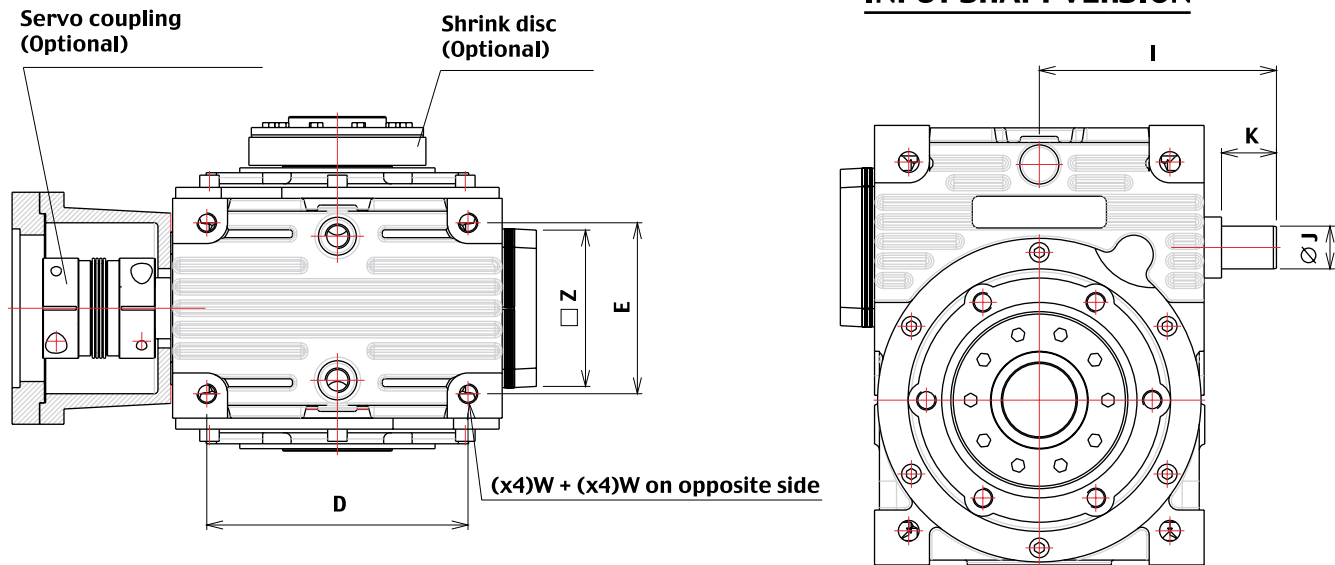

DYNABOX XL	125	160	200
A	214	284	342,5
B	302	377	483
C	107	142	171
D	214	284	342,5
E	140	150	224
F	180	198	288
F1	222	246	374
G	360	450	576
H	135	175	216
I	195	240	289
J	35	42	48
K	45	50	55
L	DEPENDS ON MOTOR		
M	185	230	300
N	160	190	250
O	17	22	28
P	163	204	251
Q	135	175	216
R	111	123	187
R1	90	99	144
S	6	6	8
S1	M16	M20	M20
T	117	129	194
T2	157	177	264
U	65	75	100
U3	80	90	140
V	145	155	230
W	M16	M20	M20
X	125	160	200
Y	4	5	5
Z	130	140	180

MOUNTING POSITIONS

	1	2	3	4
H				
V				
F				

Note : Positions F are shown with shrink disc on back side.

DYNABOX XL OUTPUT SHAFT

SINGLE OUTPUT SHAFT

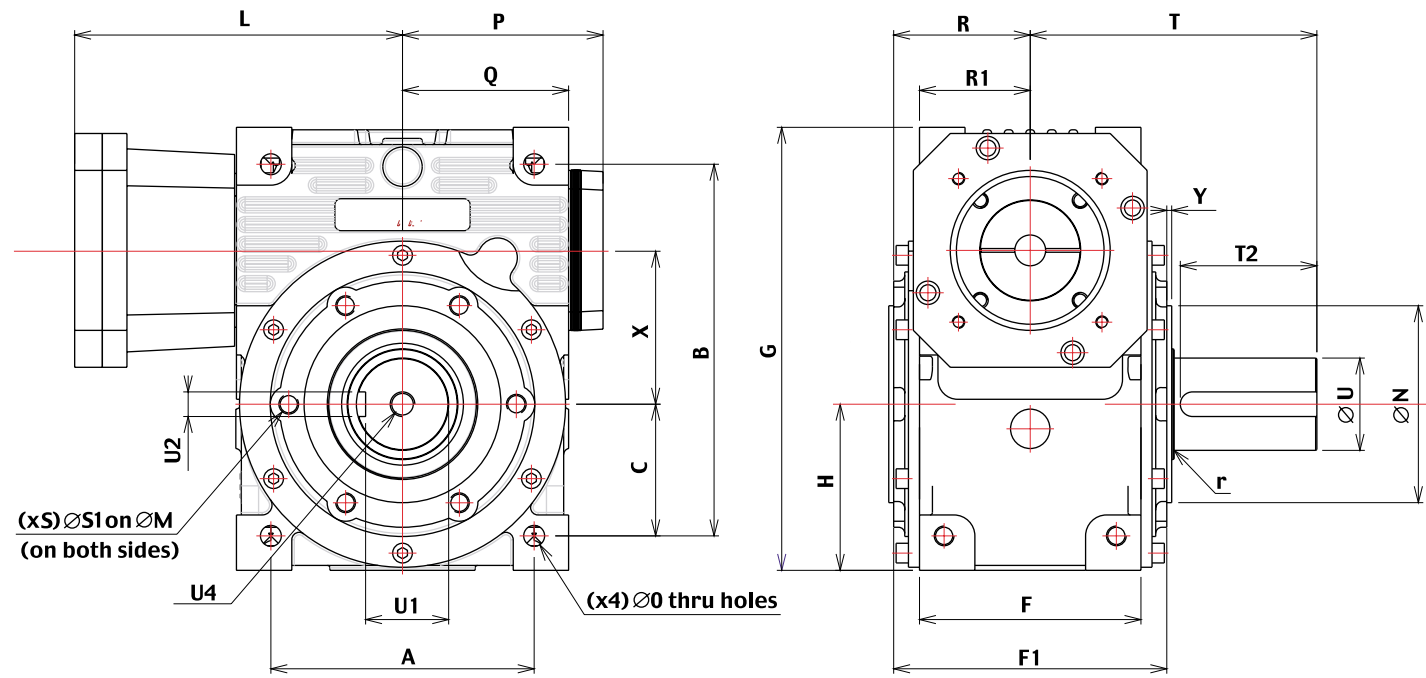

DYNABOX XL	125	160	200
A	214	284	342,5
B	302	377	483
C	107	142	171
D	214	284	342,5
E	140	150	224
F	180	198	288
F1	222	246	374
G	360	450	576
H	135	175	216
I	195	240	289
J	35	42	48
K	45	50	55
L	DEPENDS ON MOTOR		
M	185	230	300
N	160	190	250
O	17	22	28
P	163	204	251
Q	135	175	216
r	3	3	5
R	111	123	187
R1	90	99	144
S	6	6	8
S1	M16	M20	M20
T	233	269	359
T2	111	135	164
U	75	90	120
U1	67,5	81	109
U2	20	25	32
U4	M20	M24	M24
W	M16	M20	M20
X	125	160	200
Y	4	5	5
Z	130	140	180

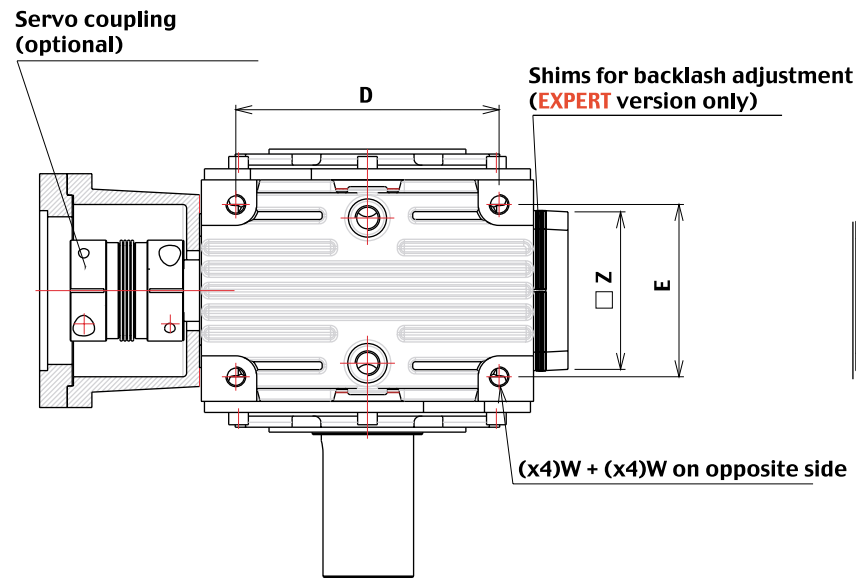

INPUT SHAFT VERSION

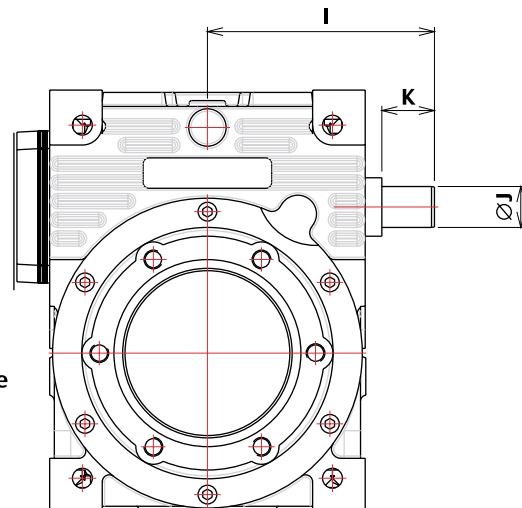

MOUNTING POSITIONS

	1	2	3	4
H				
V				
F				

CONNECTING KIT *DYNABOX XL* -SERVOMOTOR

TORSION STIFF COUPLINGS

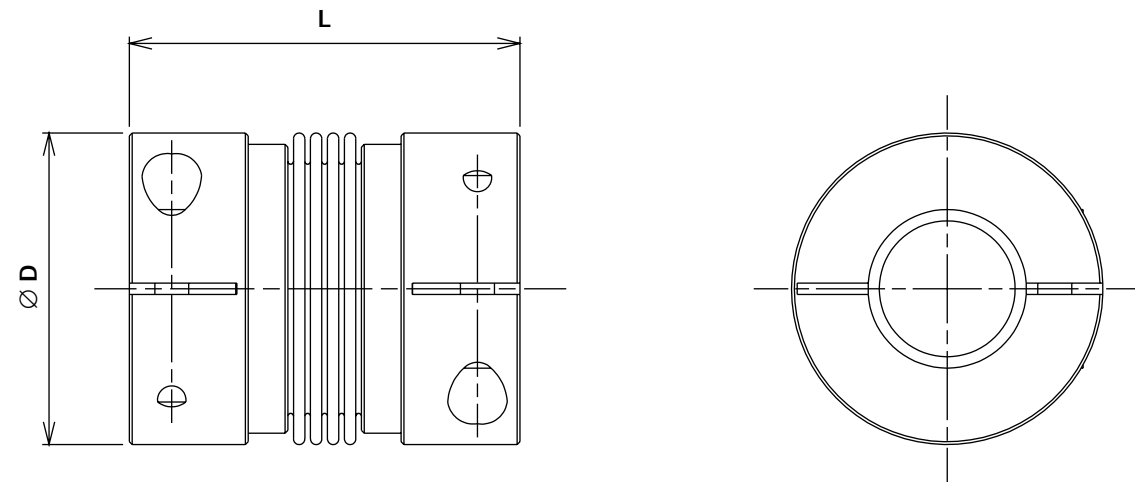

Coupling reference		AM N° 60	AM N° 80	AM N° 150	AM N° 300	AM N° 500
Ø servo shaft and <i>DYNABOX XL</i> shaft	mm	<Ø35	<Ø42	<Ø42	<Ø60	<Ø62
Servo nominal torque	Nm	60	80	150	300	500
Servo peak torque	Nm	90	120	225	450	750
Ø D	mm	66	82	82	110	123
L	mm	79	92	92	109	114
Polar moment of inertia	10 ⁻³ kgm ²	0,18	0,54	0,65	2,68	9
Torsional stiffness	Nm/mn	21	23	41	46	85

Specify the coupling reference and the servo shaft Ø when ordering.

Exemple : AM n° 150 Ø 42.

To calculate the input total inertia, add the coupling inertia to the gearbox inertia (page 5).

CONNECTING FLANGE

Select the required flange on page 11.

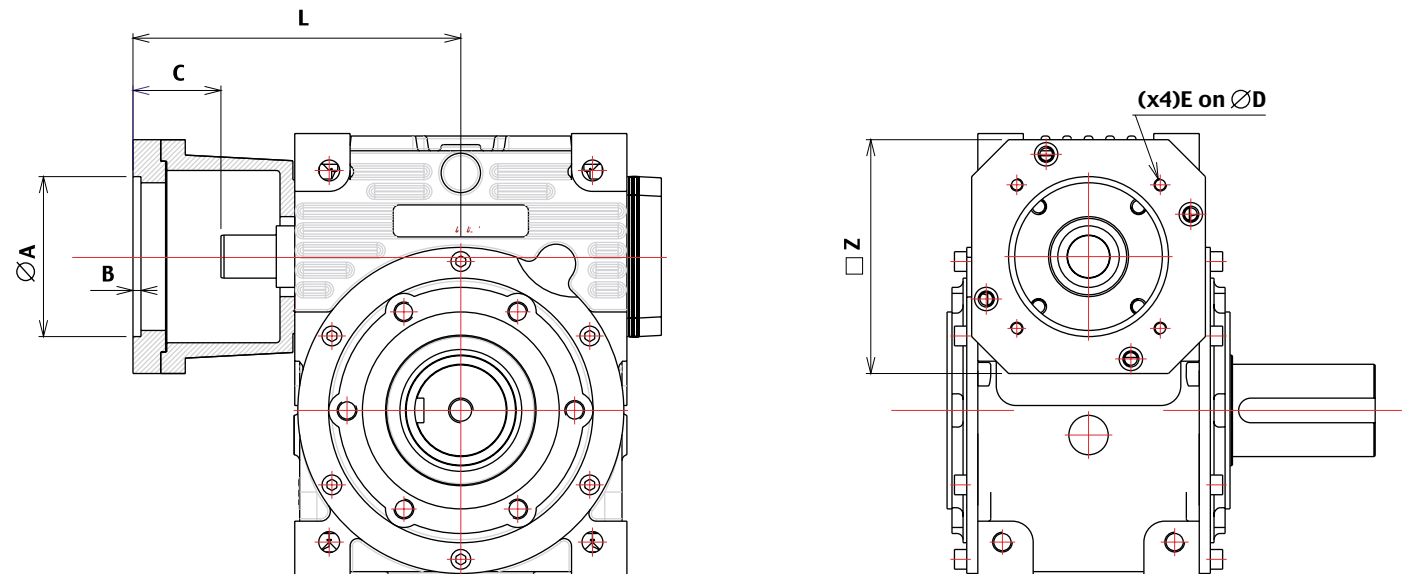

<i>DYNABOX</i>	Reference	A	B	C mini	D	E	L	Z
125	BM-F115/95	95	5	42	115	M8	247	190
	BM-F130/95	95	5	52	130	M8	257	190
	BM-F130/110	110	5	52	130	M8	257	190
	BM-F145/110	110	6,5	62	145	M8	267	190
	BM-F165/110	110	6,5	52	165	M10	257	190
	BM-F165/130	130	6,5	52	165	M10	257	190
	BM-F200/114,3	114,3	6,5	82	200	M10	287	190
	BM-F215/130	130	6,5	62	215	M12	267	190
	BM-F215/180	180	6,5	62	215	M12	267	190
	BM-F265/230	230	6,5	85	265	M12	290	260
	BM-F300/250	250	6,5	85	300	M14	290	260
	BM-F350/300	300	8,5	112	350	M16	317	360
160	BM-F165/130	130	6,5	52	165	M10	321	200
	BM-F200/114,3	114,3	6,5	82	200	M10	351	200
	BM-F215/130	130	6,5	62	215	M12	331	200
	BM-F215/180	180	6,5	62	215	M12	331	200
	BM-F265/230	230	6,5	85	265	M12	331	260
	BM-F300/250	250	6,5	85	300	M14	354	260
	BM-F350/300	300	8,5	112	350	M16	381	360
200	BM-F165/130	130	6,5	52	165	M10	365	200
	BM-F200/114,3	114,3	6,5	82	200	M10	399	200
	BM-F215/130	130	6,5	62	215	M12	379	200
	BM-F215/180	180	6,5	62	215	M12	379	200
	BM-F265/230	230	6,5	85	265	M12	402	260
	BM-F300/250	250	6,5	85	300	M14	402	260
	BM-F350/300	300	8,5	112	350	M16	429	360
	BM-F400/350	350	10,5	142	400	M16	460	420

HOW TO ORDER

Use following codification to order your *DYNABOX XL*.

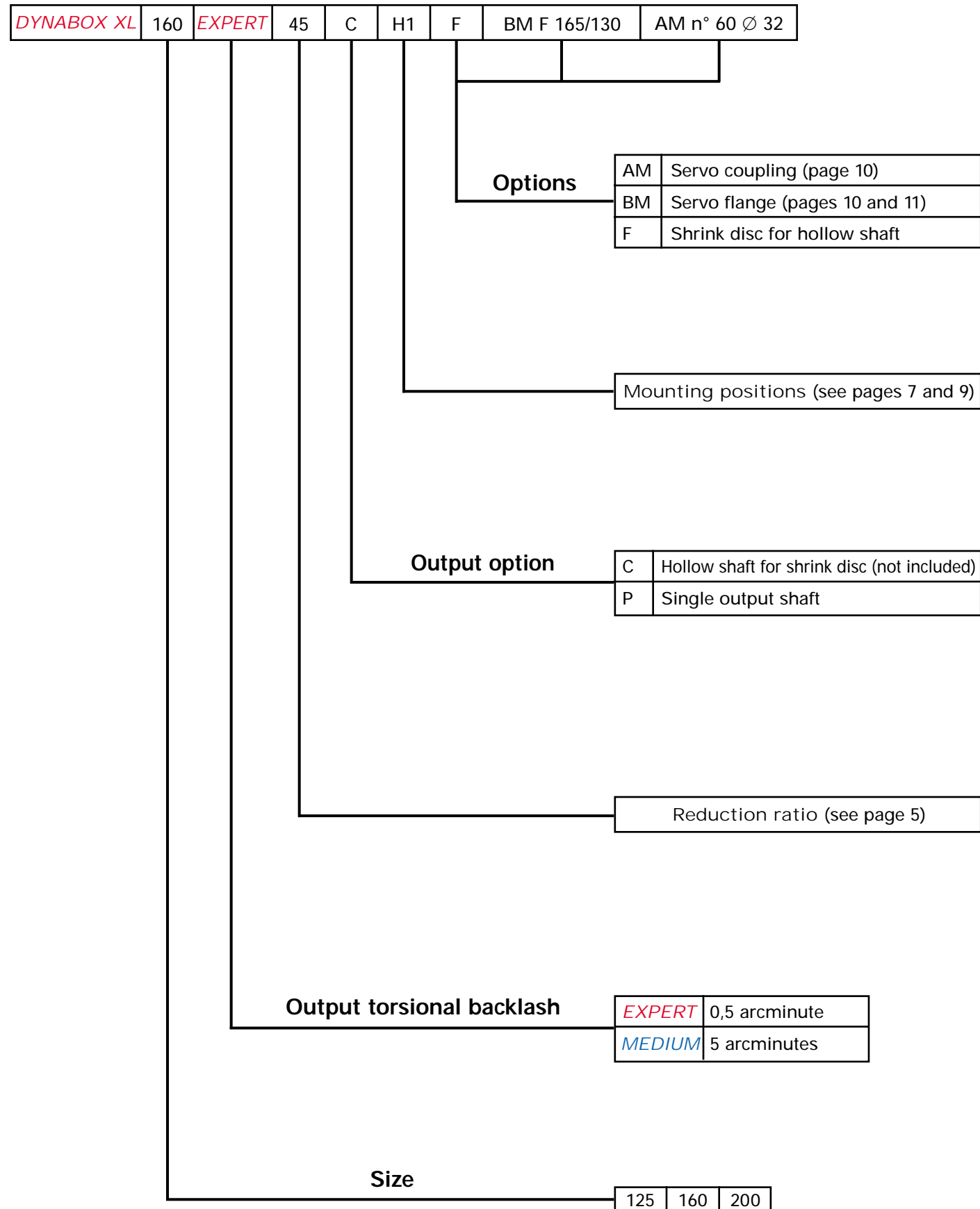

SERVO GEARSETS *DYNASET XL* WITH ADJUSTABLE BACKLASH

When *DYNABOX XL* servo gearheads cannot be used, the *DYNASET XL* servo gearsets, to be mounted in customized housing, are an interesting alternative.

Their performance are comparable to complete reducers, assuming following recommendations :

MOUNTING

Wormshaft : housing and bearing design should allow an axial shifting, necessary for backlash adjustment. The total adjustment range is obtained with a permissible displacement equal to W, as per page 14.

It is recommended, whenever possible, to use our backlash adjustment device, which is delivered preset (see page 15). The front ball bearing (see page 15) must be engaged on the shaft after the complete gear assembly, and before the backlash adjustment operation.

Wheel ring : Arrows shown on wormshaft and wheel ring must be lined up during assembly (see page 14). As the bore ØA tolerance is H6, it is recommended to grind the shaft with a tolerance k5. This will eliminate any runnout between the wheel ring and the shaft. In order to facilitate the connection between the 2 parts, heat the wheel ring up to 50°C.

After cooling, check that the wheel ring is no buckled, by applying a dial indicator on its face, while rotating the shaft.

It is recommended to use taper roller bearings on output shaft, in order to allow an axial displacement of the wheel, during the mounting operations, to center the gear

correctly. The contact pattern can be checked with Prussian blue or any similar product. A good pattern should be located slightly on the right side of the wheel tooth flanks (on both sides). It is normal to have no contact on the left side of the flanks. This gap is necessary for a good oil film forming. See sketch below.

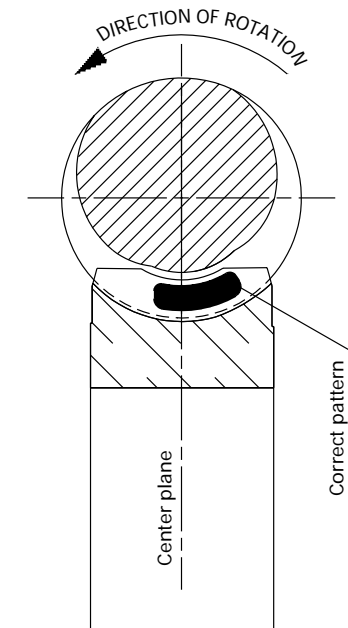

LUBRICATION

The best gear performances in terms of efficiency, life, temperature, will be achieved with a synthetic lubricant such as MOBIL SHC 634 or equivalent. The ratings shown

on page 5 can be considered only if this kind of lubricant is used.

BACKLASH ADJUSTMENT

The accuracy of our servo gearsets *DYNASET XL* allows them to be set to less than 0,5 arcminute of backlash, without any efficiency or torque capacity losses (it is assumed than custom machined parts and mounting are correct).

If our backlash adjustment device is used, simply remove some shims (delivered) between the bearing bush and

the housing, until the desired backlash value is obtained. For high speed applications, a backlash between 0,5 to 1 arcminute is recommended.

For very intermittent applications (rotary tables or milling heads of CNC machines for ex.), a backlash down to zero is tolerated, as soon as the no load input torque does not vary more than ± 30 % around the average value.

SERVO GEARSET *DYNASET XL*

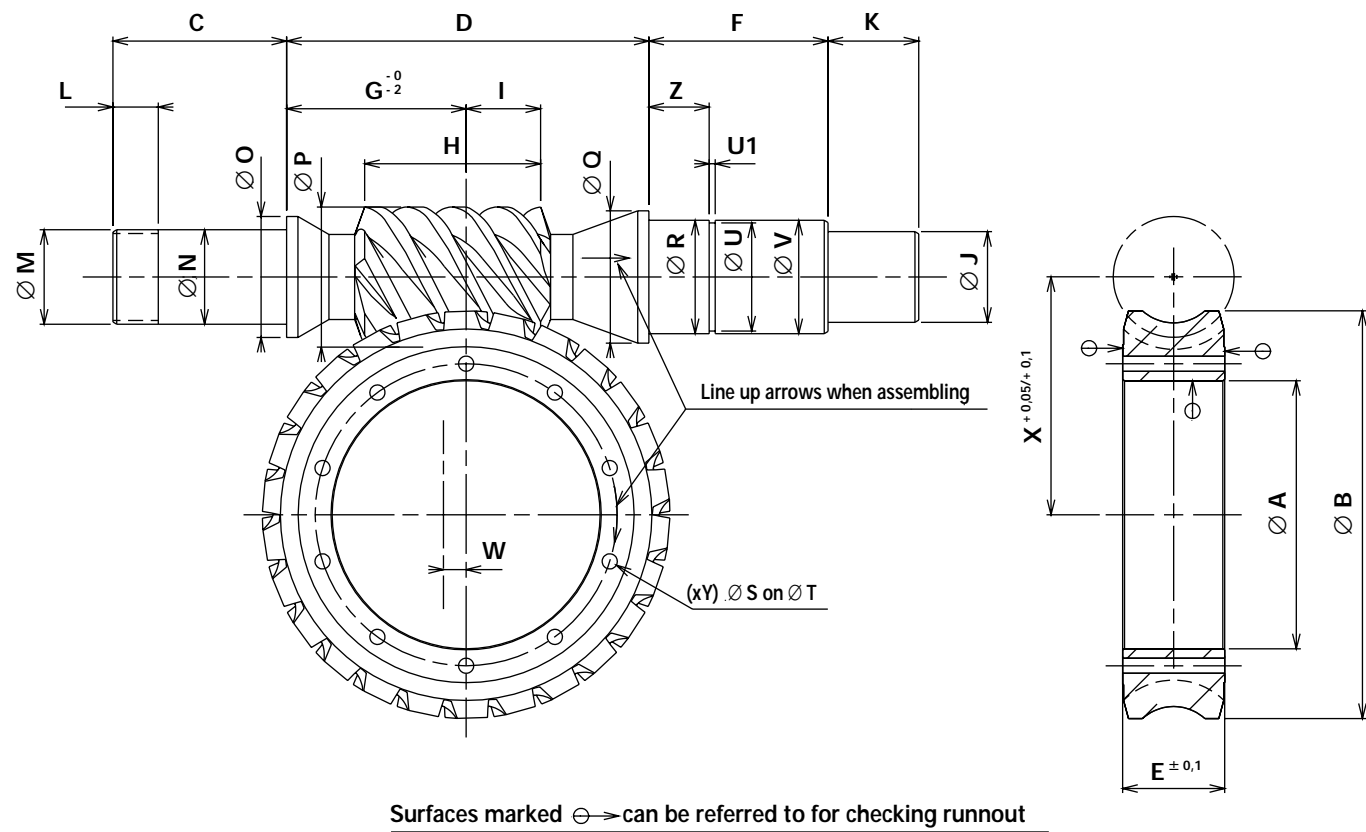

<i>DYNASET XL</i>	125	160	200
A (H6)	136	190	226
B Maxi	219	280	351
C	63	75	91
D	175	230	302,5
E	40	46	58
F	60,75	81	86,5
G	85,75	121	155
H Maxi	82	103,4	115
I Maxi	33,5	43,85	46,78
J (h6)	35	42	48
K	45	50	55
L	12	15	18
M	M35 x 1,5	M45 x 1,5	M60 x 1,5
N (k6)	35	45	60
O	44	55	72
P Maxi	53	72	84
Q	56,5	68	71
R (k6)	50	60	60
S	10,5	12,5	12,5
T	154	214	260
U	47	57	57
U1	2,15	2,15	2,15
V (c7)	50	60	60
W	10	10	10
X	125	160	200
Y	10	12	12
Z	20	22	35

BACKLASH ADJUSTMENT DEVICE FOR *DYNASET XL*

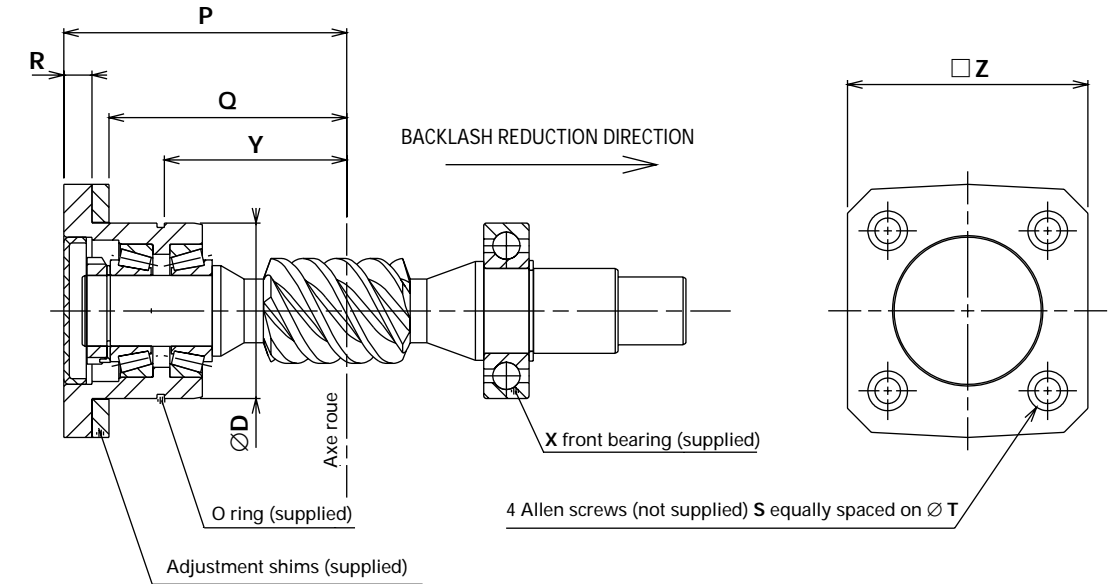

<i>DYNASET XL</i>	125	160	200
D	90	110	150
Y Maxi	111,4	150,9	191,1
Y Mini	101,4	140,9	181,1
P Maxi	163	204	251
P Mini	153	194	241
Q	135	175	216
R	18	19	25
S	M12	M12	M16
T	115	135	180
Z	130	140	180
X	6210	6212	6412

The backlash adjustment device is delivered mounted and preset.

Bearings are factory preloaded.

Backlash adjustment is operated with shims located between the housing and the bearing bush.

HOW TO ORDER

Use following codification to order your *DYNASET XL*.

