



SAX 100

DC SERVOMOTORS



SAX 100

Complete line of DC Servomotors for use with Microspeed, Microspeed Plus, Minispeed and Masterspeed Servo Amplifiers that range from 0.045 to 2.7 Nm (6.4 to 386 oz.-in.)

Typical applications are: Small Robotics, X-Y Tables, Medical Equipment, Textile Equipment, Conveyors, Graphic Machinery, Packaging Machinery, Positioners, Converting Machinery, Feeders.

STANDARD FEATURES

- ✓ Complete line of DC Servomotors starting with extremely small sizes
- ✓ Ferrite permanent magnets
- ✓ Extremely favorable cost to performance ratio
- ✓ Easy installation and use
- ✓ Full torque in a wide range of speeds
- ✓ High overload capacity
- ✓ Encoder predisposition (see table on reverse)
- ✓ Environmental working temperature: 5 ±40° C

OPTIONS

- ✓ Tachogenerator
- ✓ Brake
- ✓ Encoder fitted
- ✓ Connectors
- ✓ Terminal Box (except 117 and 130 series)
- ✓ Special flange listing available (see Catalogue)

TORQUE RANGES



DESCRIPTION

With restricted dimensions, the SAX 100 series Servomotors offer the most dynamic features along with high peak torque, therefore they are particularly suitable for driving any type of movement applications where great motion regularity, at low speed is important.

Series: **SAX 117**: 2 poles, Torque range from 0.045 to 0.75 Nm (6.4 to 10.7 oz.-in.)

Series: **SAX 130**: 2 poles, Torque range from 0.13 to 0.49 Nm (18.6 to 70 oz.-in.)

Series: **SAX 156/163**: 2 poles, Torque range from 0.46 to 0.9 Nm (65.7 to 128.6 oz.-in.)

Series: **SAX 165/175**: 4 poles, Torque range from 0.85 to 2.7 Nm (121.4 to 386 oz.-in.)

SERIES	SAX 117 (2 poles)			SAX 130 (2 poles)				SAX 156 / 163 (2 poles)				SAX 163 (2 poles)			SAX 165 / 175 (4 poles)				175 (4 poles)									
	S	M	.075	.13	.17	.3	.3	.43	.49	.49	.55	.65	.7	.75	.75	.65	.8	.9	1.15	1.0	.85	1.7	1.45	1.45	1.8	2.2	2.7	
Nm Mo (Stall Torque) (Δt=115°C) oz.-in.	.045	.06	.075	.13	.17	.3	.3	.43	.49	.49	.55	.65	.7	.75	.75	.65	.8	.9	1.15	1.0	.85	1.7	1.45	1.45	1.8	2.2	2.7	
N _n Nominal Speed RPM	3900	3500	1100	2750	2800	3200	3150	2750	2750	2800	2650	2900	3100	3000	2000	3200	2250	3000	2100	3300	4600	2250	3500	4850	3200	3400	2100	
In0 ADC (Δt=115°C)	1.4	1.7	.75	2.5	3.1	5.2	-	6.3	-	7.3	-	10	-	-	10	-	-	-	-	-	-	-	-	-	-	-	-	
BLOCKED ROTOR RATED CURRENT	65V DC	-	-	-	-	-	2.5	-	4.1	-	4	-	5.6	-	-	5.6	5.9	-	-	-	-	4.6	5.8	6.5	6.8	8.5	11.5	-
90V DC	-	-	-	-	-	-	-	-	-	-	-	-	-	-	-	-	-	-	-	-	-	-	-	-	7.4	8.8	7	
Rotor Inertia J kgm ² ·10 ⁻⁴	0.03	0.052		0.2	0.28	0.43		0.75		2.8		3.8			5			3.9			7				8.5			
Tacho (OPTIONAL)	DT03 - 3V/1000 Rpm (2 POLES)			DT10 - 10V/1000 Rpm (2 POLES)								DT10 - 10V/1000 Rpm (2 POLES)																
Tacho Inertia Jt kgm ² ·10 ⁻⁴	0.015			0.057								0.8																
Brake (OPTIONAL)	Not available			1 Nm - 24 Vdc - 0.3A								2 Nm - 24 Vdc - 0.4A																
Brake Inertia Jb kgm ² ·10 ⁻⁴	—			0.1								0.24																

Part number D.S./09.00/Sax100/01

★ AXOR IND. A COMPLETE LINE OF MOTORS AND SERVODRIVES ★

Drawings are not to scale (see quotations)

To obtain the dimensions in INCHES, divide mm by 25.4 Ex: 40 mm = 1.57 Inches / 25.4

MECHANICAL DIMENSIONS

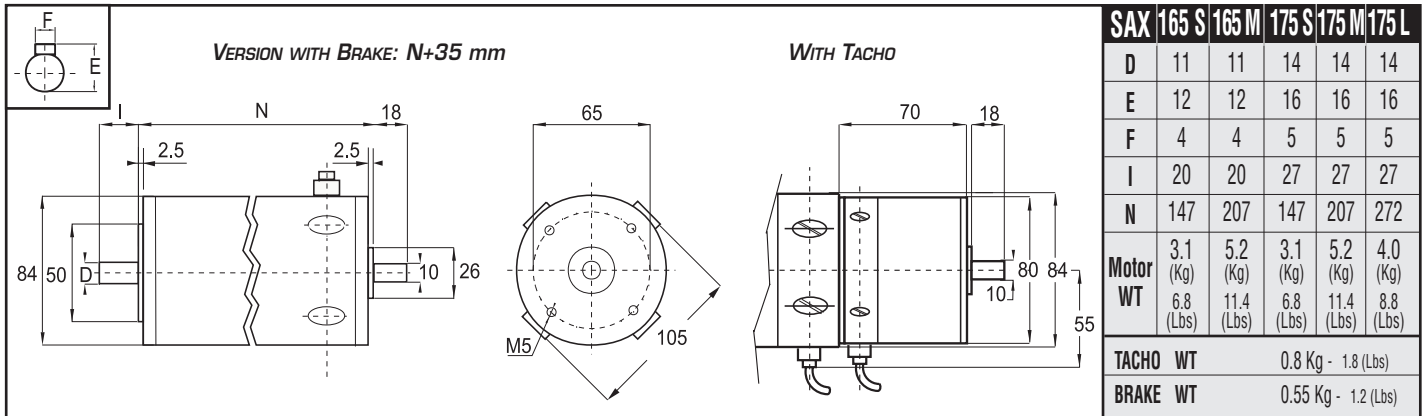
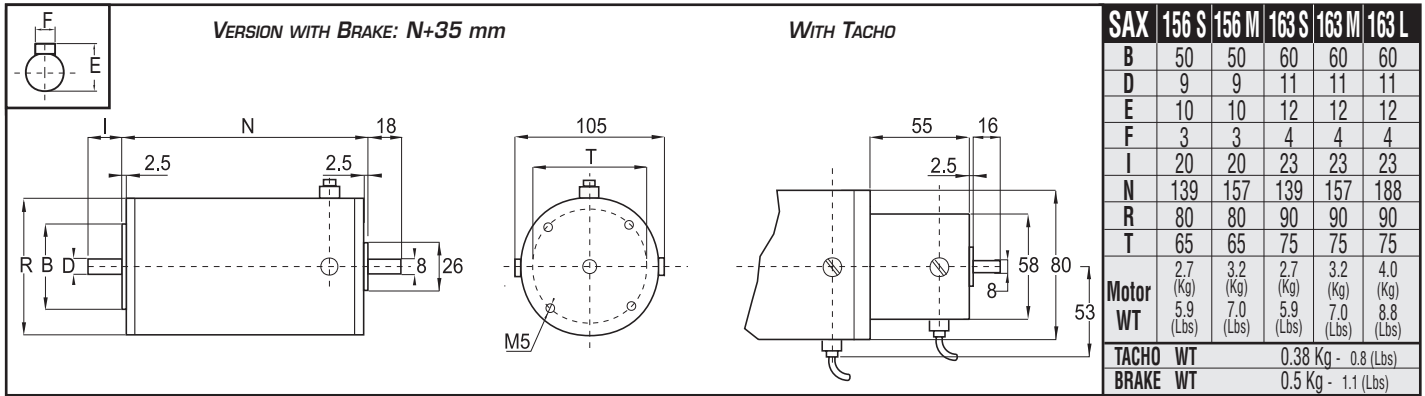
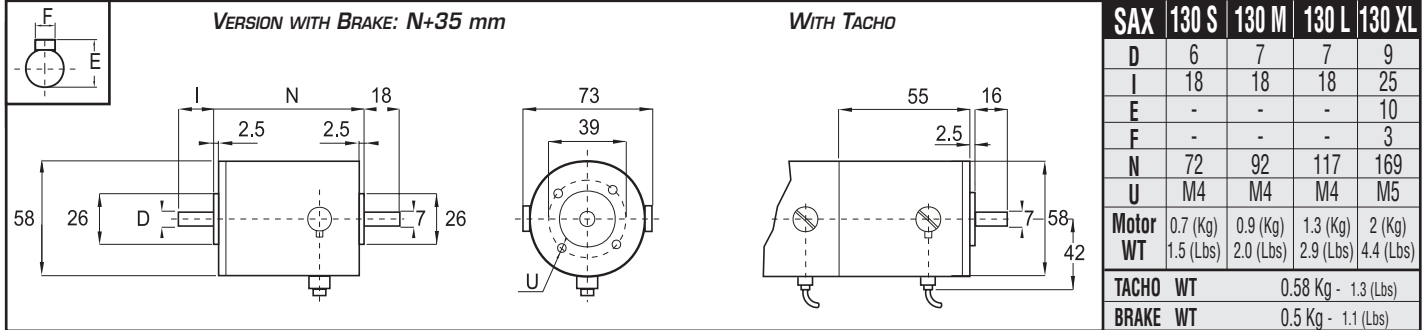
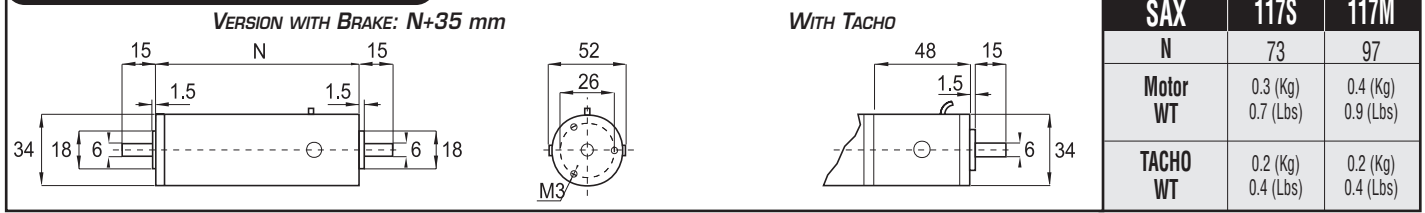

ORDERING CODE

Example:

SAX - 117 - S 3.90 / 024 - XX - 09 - P - 00

NAME: Line of DC Servomotors

SERIES: 117, 130, 156, 163, 165 or 175

SIZE: S, M, L or XL

NOMINAL SPEED: (KRPM) Ex: 3.9-3900 Rpm (see table on reverse)

NOMINAL VOLTAGE: 24, 48, 65 or 90Vdc (at nominal speed)

FLANGES & SHAFTS: XX = Standard (see above)

CUSTOM MADE:
00 = Standard

ELECTRICAL CONNECTIONS:

P = Flying leads
C = Connectors (optional)
F = Fast-on

OPTIONS: 09 = Only motor (standard)

01 = With Tacho

06 = Brake+Tacho

...other solutions in our catalogue



Specifications subject to change without notice. This document has been carefully checked. However, Axor does not assume any liability for errors or inaccuracies.

© COPYRIGHT 2000 AXOR INDUSTRIES. All rights reserved. Printed in Italy, 09/00



AXOR IND.

via Cà Sordis 6/g - 36054 Montebello Vic.no - Vicenza - Italy

phone: (8 l. n.a.) (+39) 0444 440441 - (+39) 0444 440988

fax: (+39) 0444 440418



OFFICIAL-DEALER