

Nema 42

2 phase 1.8° step angle
 hybrid stepping motor

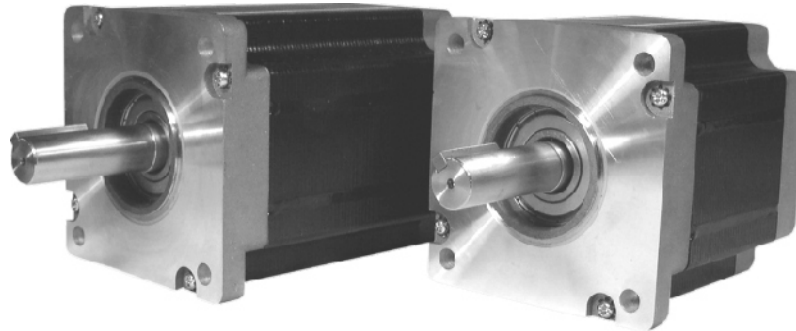

Specifications:

Model	Holding Torque (Nm)	Phase current (A)	Rotor Inertia (g/cm ²)	Motor Length L max (mm)	Detent Torque (Nm)	Phase Resistance (ohm)	Phase Inductance (mH)	Lead Wire (No)	Motor Weight (Kg)	Note
M1433010	14.4	10	5500	116	0.45	0.24	3.3	8	6.3	Bip. parallel
M1433020	21	10	11000	150	0.65	0.33	5.0	8	8.5	Bip. parallel
M1433040	29	10	15000	201	0.80	0.45	8.0	8	11.7	Bip. parallel

Double shaft and custom windings available

Mechanical Dimensions:
 Unit: mm

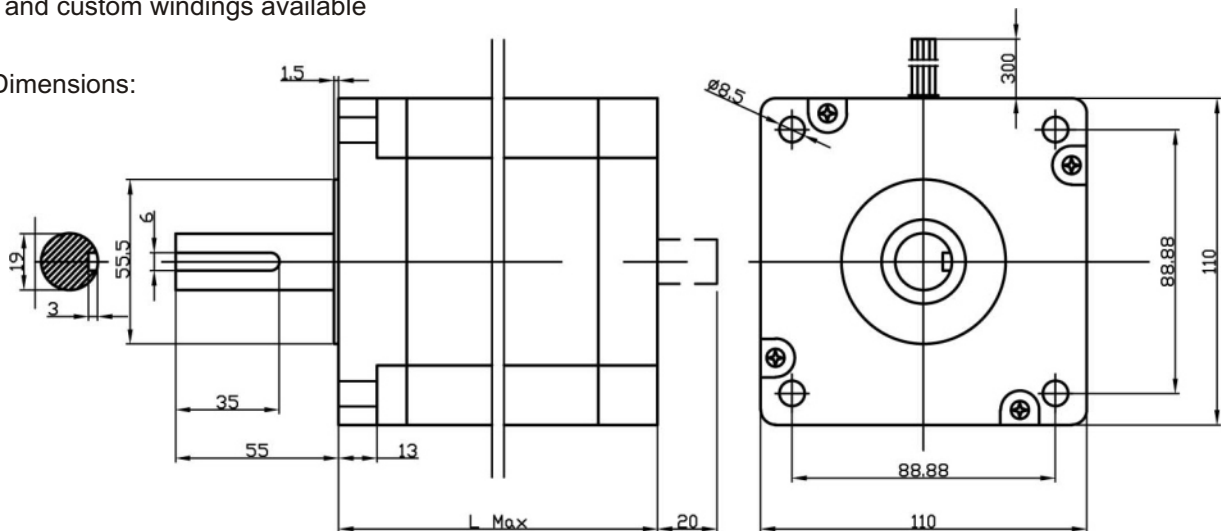

Wiring Diagram:

