

Magnetic absolute rotary encoder

▶ GEL 2037

with heavy duty flange
or tooth wheel adapter



General

- ▶ Multiturn absolute rotary encoders with a resolution of up to 25 bits in a compact design
- ▶ Magneto-resistive scanning of a diametral magnet provides unambiguous position values at every angular position via the SSI interface
- ▶ Magnetic scanning is not subject to ageing and is resistant to temperature fluctuations, contamination or condensation.
- ▶ Redundant position signal can be provided by integrated resolver

Features

- ▶ Total resolution 25 bits
- ▶ Absolute accuracy 0.8°
- ▶ Output signal SSI or SSI and resolver
- ▶ Magnetic gear

Advantages

- ▶ Suitable for all standard applications and also for real heavy-duty applications
- ▶ Withstands high shock/ vibration loads
- ▶ Not affected by dirt or oil mist
- ▶ Temperature behaviour stable over the long-term
- ▶ Full function in case of condensation: dew-point resistant!
- ▶ No ageing of the magnetic sensor technology

Field of application

- ▶ Construction machines
- ▶ Agricultural machines
- ▶ Food industry
- ▶ Wind power
- ▶ Offshore technology



Description

Construction and design

The encoder housing made of anodised aluminium has a flange dimension of 58 mm. The absolute rotary encoder GEL 2037 is suitable for standard and heavy-duty applications, it also withstands aggressive media and impresses with a long, maintenance-free service life.

The GEL 2037 is available with a heavy-duty flange or clamping flange with tooth wheel adapter.

A very compact redundant system is realised by combination with a resolver. The complete electrical isolation of the resolver from the magnetic absolute rotary encoder ensures true redundancy of the absolute position values.

Sensing principle

The GEL 2037 is based on the contactless magnetic scanning of a diametral magnet. Magnetoresistive sensors measure directly the absolute position within a turn and a magnetic gear supplies the number of turns.

The multiturn absolute rotary encoders in the GEL 2037 series provide an unambiguous position value for each angular position with a resolution of up to 25 bits. In the process, the singleturn stages operate with a resolution of up to 13 bits. The multiturn stage is based on a magnetic gear that saves the number of turns in a non-volatile form.

The magnetic absolute rotary encoder supplies the position values in binary or gray code via a synchronous serial interface, (SSI).

The synchronous serial interface transfers the position data at a clock frequency of up to 1 MHz. Prior to further position sampling, a minimum clock pulse space of 25 μ s must be met.

Temperature ranges

High precision SMD components are used in the absolute rotary encoder. Despite careful selection, thermal ageing of these components cannot be excluded. For this reason the encoder should be stored at a temperature from -40 °C to 85 °C.

Operating temperatures of -40 °C to 85 °C are allowed, an installed absolute rotary encoder is not allowed to exceed this temperature range. The function of the absolute rotary encoder is ensured within the operating temperature range allowed, (DIN 32878); here it is the temperature at the encoder housing that applies.

The temperature of the absolute rotary encoder is affected by the installation situation (thermal conductance, thermal radiation), the heating caused by the absolute rotary encoder (bearing friction, electrical power loss) and the ambient temperature. The operating temperature may be higher than the ambient temperature depending on the operation of the absolute rotary encoder.

Depending on the supply voltage the heating caused by the encoder can be up to 10 °C. At high operating speeds > 5,000 min^{-1} the heating caused by the encoder can be up to 20 °C due to the bearing friction.

If the absolute rotary encoder is operated close to the limits of the specifications allowed, the ambient temperature must be reduced by suitable means (cooling) such that the operating temperature range allowed is not exceeded.

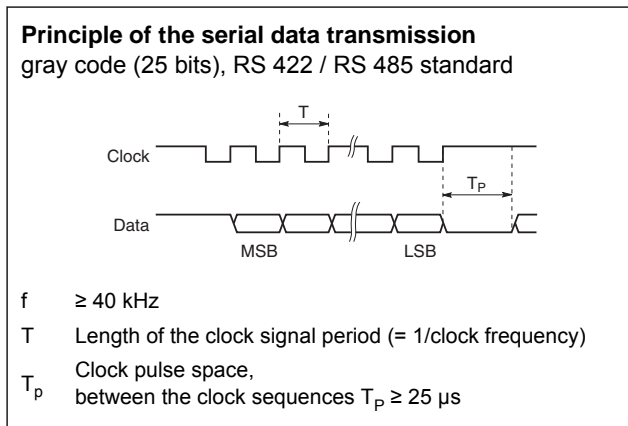

Technical data

	SD	SR	TD
General			
Incremental deviation	< 0,01°		
Absolute accuracy (DIN 32876)	0,8°		
Electrical data			
Supply voltage	10 to 30 V with reverse voltage protection		5 V ± 5% without reverse voltage protection
Power consumption	400 mW		
Single turn resolution	8192 steps per revolution (13 Bit)		
Multi turn resolution	4096 steps per revolution (12 Bit gear)		
Digital interface	SSI (max. transmission rate 1 MHz)		
Mechanical data			
Moment of inertia of rotor	611.8 x 10 ⁻⁶ kgm ²		
Werkstoffe	Aluminium anodised		
Weight	450 g		
Operating speed (limit)	6,000 min ⁻¹		
Shaft load (radial/axial)	265 N / 100 N, at 100 min ⁻¹		
Bearing life	> 10 ⁵ h at 1,000 min ⁻¹		
Environmental data			
Operating temperature range	-40 °C to 85 °C		
Working temperature range	-40 °C to 85 °C		
Storage temperature range	-40 °C to 85 °C		
Protection class according to DIN 60529	IP 67		
Vibration resistance (DIN EN 60068-2-6)	200 m/s ² , 10 to 2,000 Hz		
Shock protection (DIN EN 60068-2-27)	2000 m/s ² , 11 ms		
EMC	EN 61000-6-1 to 4		
Isolation resistance	Ri > 1 MΩ, at a testing voltage of 500 V AC		
Relative humidity max.	99 %		
Condensation	permissible, according to DIN EN 60068-2-30 Part 2 of 1999		

Interfaces

Synchronous serial interface

Direction of rotation

The encoder can output increasing position values on the clockwise or counter clockwise rotation of the shaft. The direction of rotation can be selected by using the CW/CCW input (counting direction).

Position values on the clockwise rotation of the shaft	
Standard:	
GND on CW/CCW	Increasing pos. ↑
or not connected:	
Inverse:	
V_S on CW/CCW:	Reducing pos. ↓

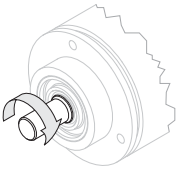

Cable length

With the synchronous serial interface protocol the transmission rate allowed drops with increasing cable length. A screened, twisted pair cable is recommended for the signal cables (\pm CLOCK and \pm DATA).

Cable length [m]	< 50	< 100	< 200	< 400
Clock frequency [kHz]	< 400	< 300	< 200	< 100

PRESET function

The output signals can be set to a PRESET value from any position. As supplied the encoder is set to half the maximum resolution. The PRESET is set electronically if the supply voltage V_S is briefly $t > 100$ ms applied to the PRESET input (do NOT apply continuously). As an alternative there is a PRESET push-button recessed into the base of the housing (IP 67). The PRESET push-button can be operated using a pin ($t > 100$ ms). Other PRESET values are available on request.

After activation of the PRESET function the value is available immediately internally, but is only transmitted via SSI after 3 s.

The PRESET function and the direction of rotation (SSI) are disabled from a threshold of 2 V on the input pin.

Preset push-button

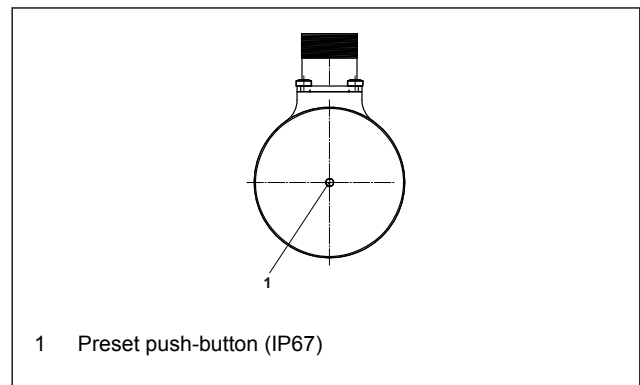

Resolver

A resolver is integrated into the rotary encoder GEL 2037 SR. This supplies a redundant position signal within a turn.

Resolver configuration

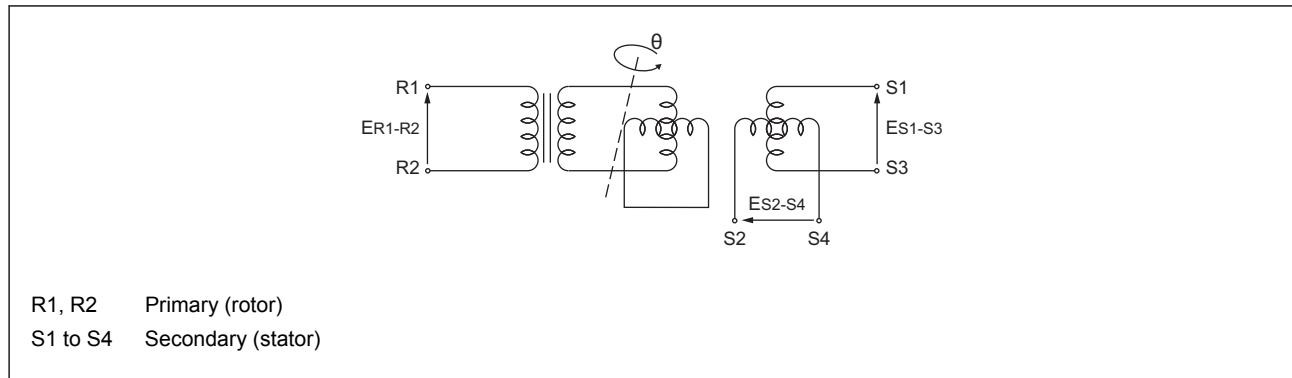

Technical data of resolver	
Input voltage	7 V rms
Primary	$E_{R1-R2} = E \sin \omega t$
Secondary	$E_{S1-S3} = K E_{R1-R2} \cos \Theta$, $K =$ conversion ratio $E_{S2-S4} = K E_{R1-R2} \sin \Theta$
Input frequency	10 kHz (max. permissible deviation $\pm 5\%$)
Conversion ratio	$0.5 \pm 5\%$
Precision (measurement errors)	$\pm 10'$
Zero potential	max. 20 mV rms
Phase separation	Nominally 0°
Speed ripple	max. 1.5 % at 1,500 min ⁻¹
Insulation resistance	100 M Ω at 500 V DC
Input current	max. 80 mA

Dimensional drawing

Dimensional drawing GEL 2037 – heavy-duty flange

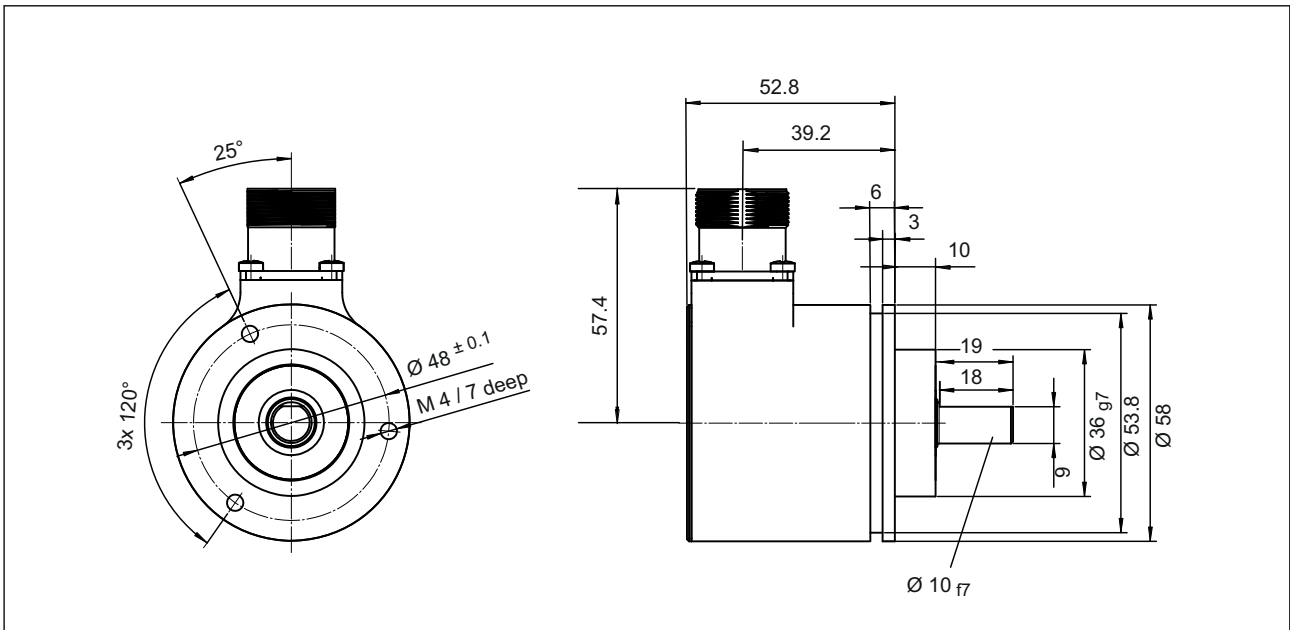

Dimensional drawing GEL 2037 – clamping flange with tooth wheel adapter

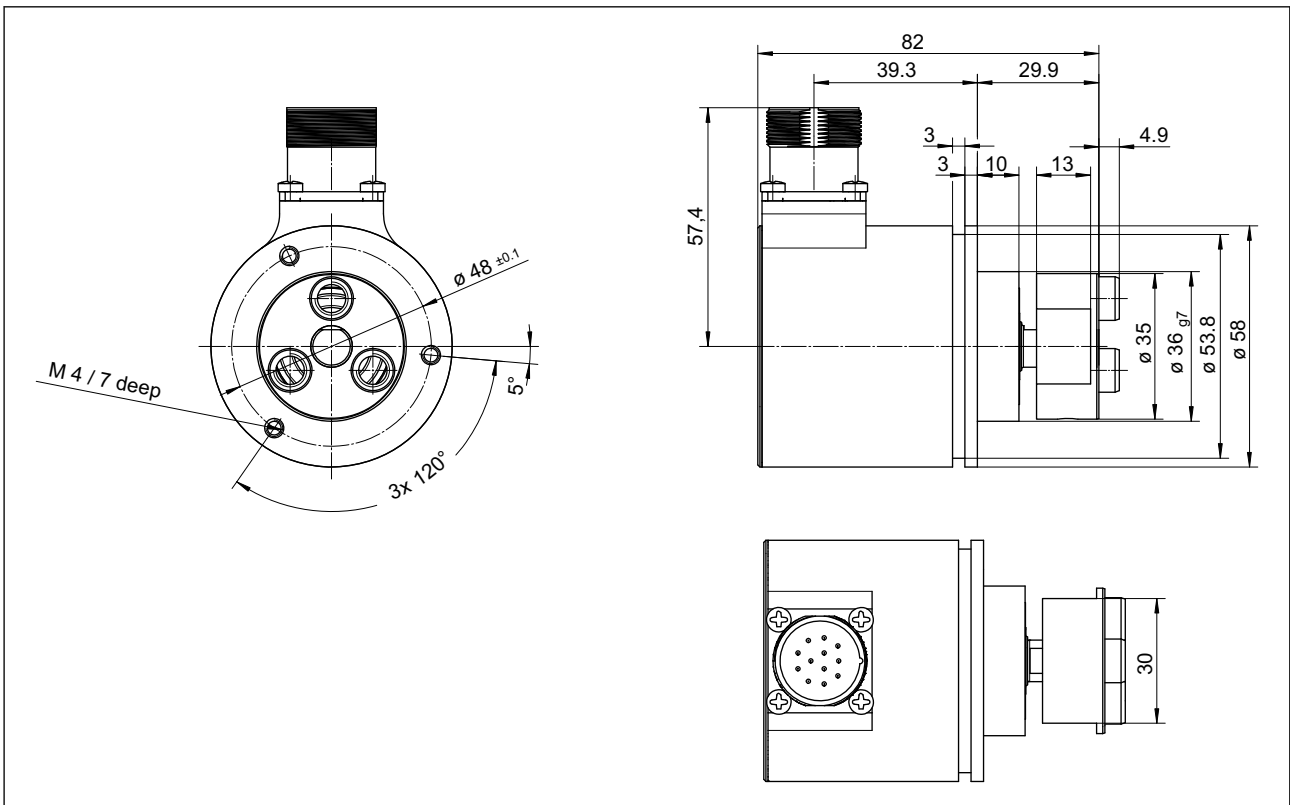

Connector assignment SSI interface (SD, TD)

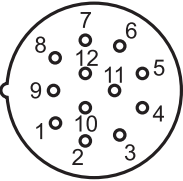
Connection	PIN	Signal	Description
Connector M23, 12-pin 	1	GND	Earth
	2	Data+	Differential data signal in accordance with RS 485
	3	Clock+	Differential clock signal in accordance with RS 485
	4	Sense-	5 V voltage monitoring (only for TD)
	6	Sense+	5 V voltage monitoring (only for TD)
	7	CW/CCW	Direction of rotation
	8	U_B	Operating voltage, ⁽¹⁾
	9	PRESET	Electronic adjustment $U_B, t > 100$ ms
	10	Data-	Differential data signal in accordance with RS 485
	11	Clock-	Differential clock signal in accordance with RS 485

Connector assignment SSI interface with resolver (SR)

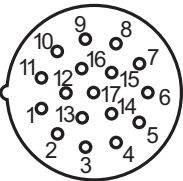
Connection	PIN	Signal	Description
Connector M23, 17-pin 	1	R1	Resolver signal
	2	R2	Resolver signal
	3	S4	Resolver signal
	4	S3	Resolver signal
	5	CW/CCW	Direction of rotation
	6–7	–	Not used
	8	Clock-	Differential clock signal in accordance with RS 485
	9	Data-	Differential data signal in accordance with RS 485
	10	GND	Earth
	11	U_B	Operating voltage, ⁽¹⁾
	12	PRESET	Electronic adjustment $U_B, t > 100$ ms
	13	S2	Resolver signal
	14	S1	Resolver signal
	15	Clock+	Differential clock signal in accordance with RS 485
	16	Data+	Differential data signal in accordance with RS 485

⁽¹⁾ to suit interface variant (→ page 3)

Type code GEL 2037

2037	Interface	
	SD	SSI
	SR	SSI and resolver
	TD	SSI 5 V
	Code	
	B	Binary code
	G	Gray code
	Resolution per revolution	
	13	13 Bit, 8192 steps per revolution
	12	12 Bit, 4096 steps per revolution
	Number of revolutions	
	12	12 Bit, 4096 revolutions
Flange / Shaft		
G	Heavy-duty flange D = 10 mm / L = 20 mm	
H	Clamping flange D = 10 mm / L = 20 mm with tooth wheel adapter	
Electrical interface		
E	12-pole connector outlet, type M 23, radial	
F	17-pole connector outlet, type M 23, radial (SSI+Resolver only)	
Connector / cable		
S	connector	
IP protection class		
1	IP 65	
4	IP 67 (only PRESET function)	
Option		
0	without option	

Customer-specific designs

Customer-specific modifications to mechanical and electrical features are in principle possible.

Accessories

Description	Item number
Metal coupling MK 8, inside diameter: 5 to 12 mm (state shaft diameter)	MK 8
Metal coupling MK 12, inside diameter: 6 to 15 mm (state shaft diameter)	MK 12
Clamp coupling KK14, inside diameter: 6 to 16 mm (state shaft diameter)	KK 14
Clamping elements (3 pieces)	KL 200
12-pole mating connector M23, straight	GG126
17-pole mating connector M23, straight	FS 11311

Subject to technical modifications and typographical errors.
The latest version can be downloaded at www.lenord.com.

