

General

The multichannel rotary encoder was specially designed for the requirements of the rail vehicle industry. The rotary encoder was designed such that it supplies independent output signals for different control system electronics such as motor speed sensing, anti-skid protection, train control and rolling distance measurement. Depending on the requirements, up to 8 output channels can be configured.

The measuring scale is of robust design so that it can even withstand extreme impacts and vibration. The magnetic sensors are resistant to harsh environmental conditions such as dirt, oil, humidity or condensation due to temperature differences. The rotary encoder contains bearings that ensure maintenance-free, durable operation in the harshest operating conditions.

All types can be customised with various cables, protective sleeves and connectors.

Features

- Max. 8 channels
- Max. 3 different pulse numbers
- Voltage or current output
- Various flange forms for every vehicle type

Advantages

- Solution individually tailored to the specific application, as numerous combinations of channels and pulse numbers possible
- Due to the flexible design the rotary encoder is not only ideal for new projects, but also excellently suited to upgrades.
- Maintenance-free, durable operation in the harshest ambient conditions due to selected bearings and a magnetic measuring system

Field of application

- Rail vehicle industry
 - Traction monitoring
 - Ant-slip protection
 - Anti-skid protection
 - Motor rotational speed



Right to technical changes and errors reserved.

Description

Concept

The rotary encoders GEL 27xx are intended for the measurement of the speed of rotational movements in rail transport systems. They are designed as an application-specific encoder system and can be mounted on bogies with inside or outside bearings.

All rotary encoders GEL 27xx are manufactured to drawing or an application description. The technical specifications may vary from the technical data given. The modified specifications and the pin layout are to be found on the customer-specific dimensional drawing.

Rotary encoder types

Types GEL 2710 and 2712 are appropriate for bogies with outside bearings. They are flanged onto the bearing cover of the wheel set and driven by a clutch disc, for instance. The type GEL 2701 is suitable for bogies with inside bearings. A rotor flange is mounted on the wheel set; the rotary encoder can turn freely on the flange. Fixing the cable hose prevents the encoder from simultaneous rotation. Various flange shapes and drives are available.

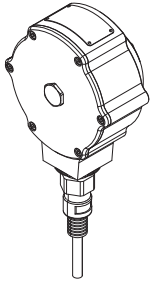
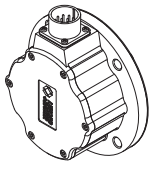
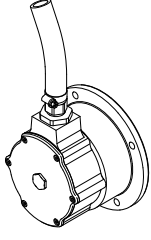
Rotary encoder type	Design example
Rotary encoder GEL 2701	
Rotary encoder with round flange GEL 2710	
Rotary encoder with adapter flange (cover) GEL 2712	

A Y number is assigned to customer-specific designs, this letter is appended to the product identifier (GEL 27xxYxxx).

Function

Inside the rotary encoder there is a metal measuring scale that is connected to the shaft. This measuring scale is scanned by one or several magnetic sensors. Electrical pulses are generated in the sensors by the rotating measuring scale. The integrated electronics convert these pulses into square-wave voltage or current signals.

The output frequency is proportional to the rotational speed of the axle. The signals are evaluated in the vehicle control electronics.

Multichannel

The incremental rotary encoder has 1 to 8 output channels. These channels can be configured as single channels or in groups with a fixed phase relationship. A typical configuration would be the arrangement of two sensors offset electrically by 90° for additional detection of direction. Other arrangements such as three sensors offset by 120° or a single channel and two sensors offset by 90° as a group are possible.

The channels can all be operated with a common power supply or, if required, electrically isolated with different supply voltages from 10 to 30 VDC.

The rotary encoder can supply up to 3 different pulse numbers. These pulse numbers can be allocated to the output channels or the groups of output channels as required.

Combination of channels and pulse numbers - example

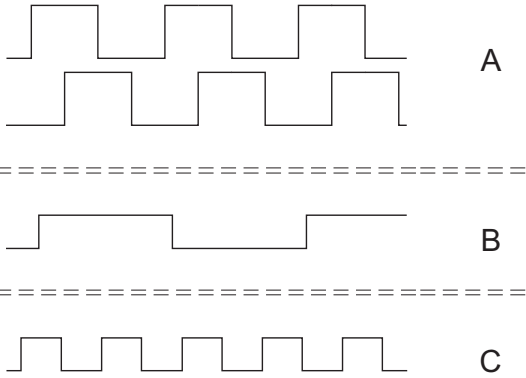
		
A	2 channels with 90° phase offset 110 pulses per turn 24 V DC supply voltage	Motor rotational speed
B	1 channel 55 pulses per turn 15 V DC supply voltage	Anti-skid protection
C	1 channel 200 pulses per turn 15 V DC supply voltage	Train control

Technical data

General	
Number of channels	1 to 8
Phase offset ⁽¹⁾	Standard: 90° electrical others possible (e.g. 120°)
Duty	50% ± 10%
Resolution (pulse numbers)	200, 110, 100, 80, 55, 12
Electrical data for encoder with voltage output	
Supply voltage U_B (polarity reversal protected)	10 to 30 V DC
Current consumption per channel I_S (without load)	≤ 30 mA
Output signal (short-circuit-proof)	Square-wave signals
Output frequency	0 to 20 kHz
Output signal level High	≥ $U_B - 2.0$ V
Output signal level Low	< 2.0 V
Electrical data for encoder with current output	
Supply voltage V_S (polarity reversal protected)	12 to 16 V DC
Output signal (short-circuit-proof)	Square-wave signals
Output frequency	0 to 20 kHz
Output signal level High	Typ. 14 mA
Output signal level Low	Typ. 7 mA
Voltage drop	4 V
Load that can be connected	$(U_B - 4$ V) / 16 mA
Mechanical data	
Max. permitted rotational speed	5000 min ⁻¹
Shaft material	Stainless steel
Housing material	Coated aluminium
Weight (without cable, without drive)	
GEL 2701	1400 g
GEL 2710	2000 g
GEL 2712	2000 g
Operating temperature	-40 °C to +100 °C
Storage temperature range	-40 °C to +105 °C
Protection class	IP 67
Vibration protection	EN 61373:2011-04 cat. 3
Shock protection	EN 61373:2011-04 cat. 3
Electromagnetic compatibility	Rail vehicles (EN 50121-3-2:2017-11)
Insulation strength	1.5 kV, 50 Hz, 1 min. (EN 50155:2018-05)
Type test	EN 50155:2018-05 IEC 60571:2012
Atmospheric humidity	100 %
Condensation	Permitted
Electrical connection	
Cable, connector, protective sleeve	Depending on device type, specification on request

⁽¹⁾ between two or more channels

Output signals

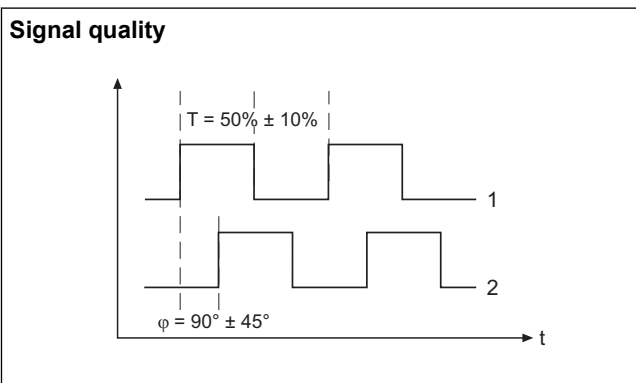
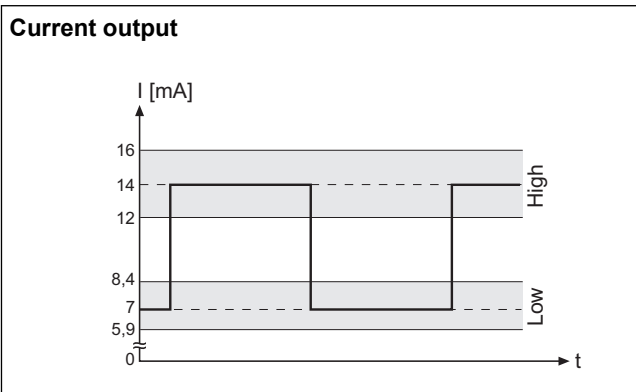
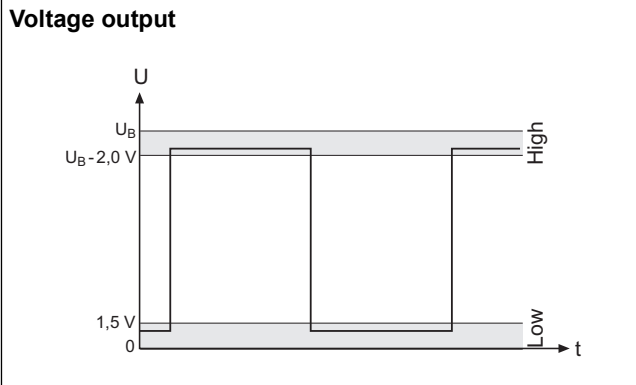

- T Duty
- ϕ Phase
- 1 Channel 1
- 2 Channel 2

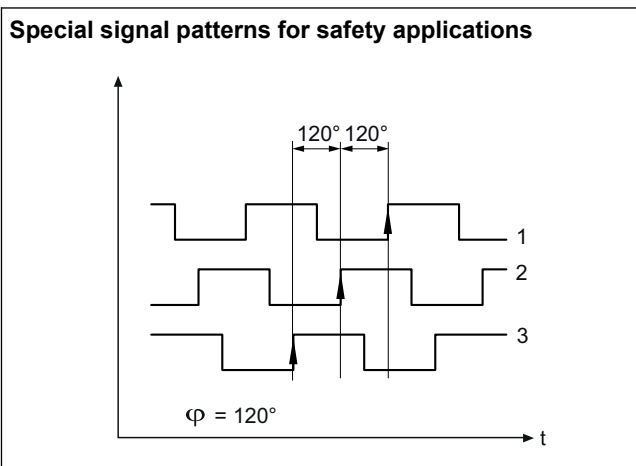

Special signal patterns for safety applications are available on request:

- 3 channels with 120° phase shift

Dimensional drawing

Dimensional drawing rotary encoder GEL 2701 with rotor flange mounted (drive example 1)

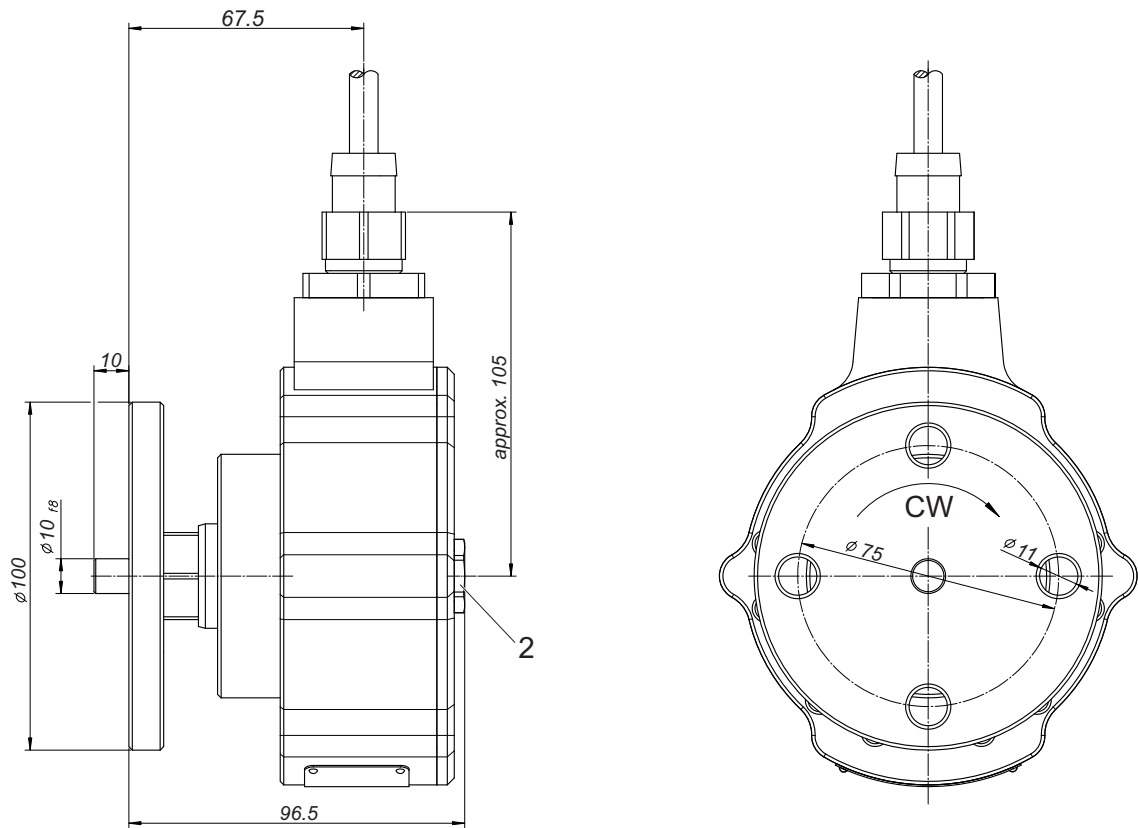

All dimensions stated in mm

2 Blanking plug, SW 24

CW Direction of rotation of the rotor shaft

Torque support is necessary.

GEL 2701 – drive example 1

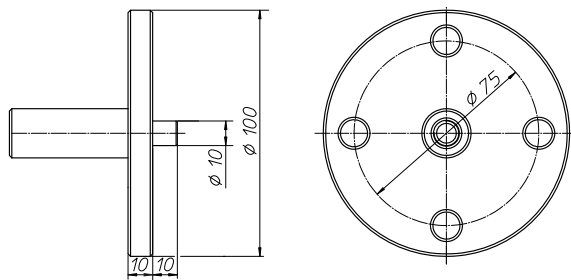

GEL 2701 – drive example 2

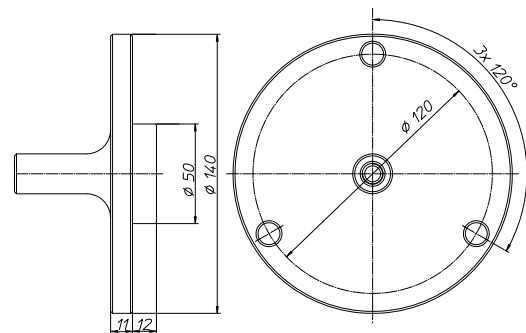

Rotor flanges can be supplied in various dimensions for different applications.

Dimensional drawing

Dimensional drawing rotary encoder with round flange GEL 2710

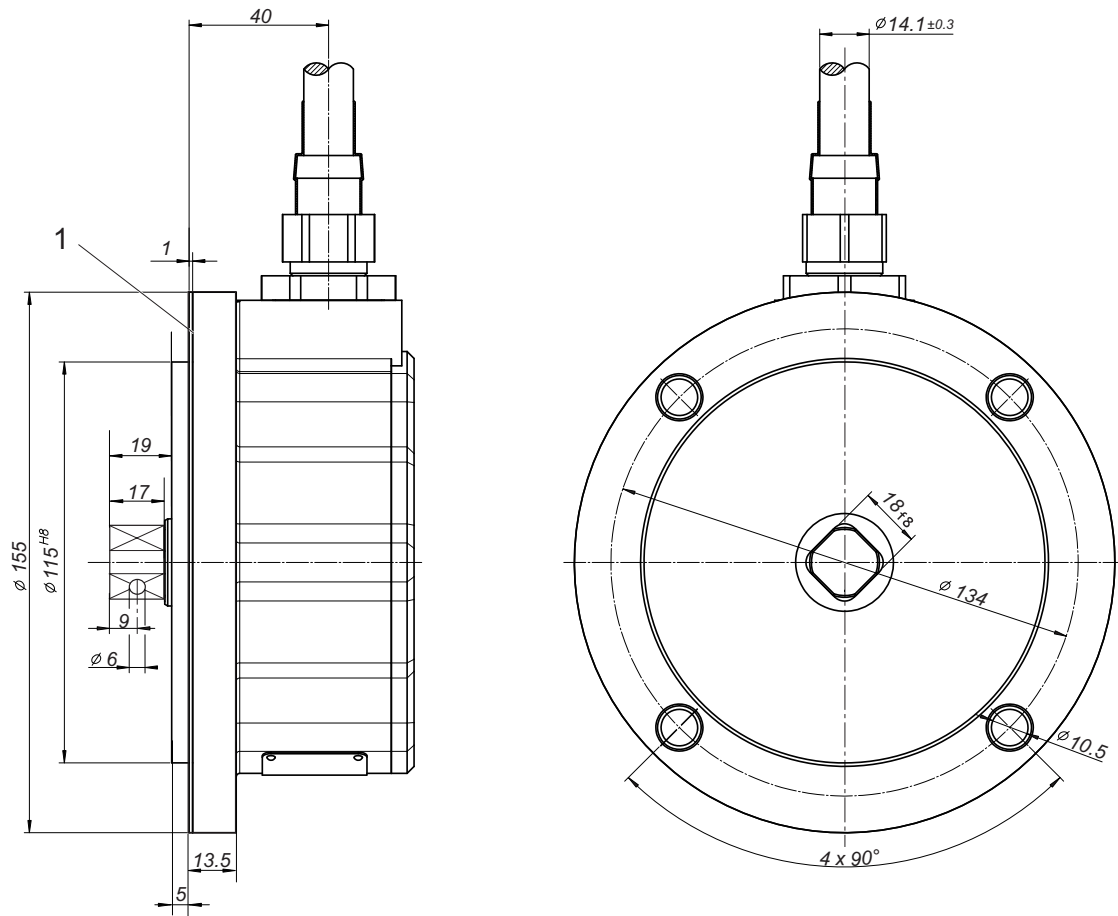

All dimensions stated in mm

1 Seal, thickness 1 mm

GEL 2710 – drive example 1

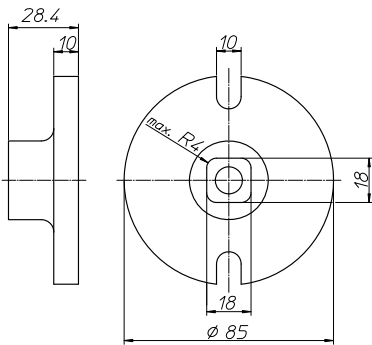

GEL 2710 – drive example 2

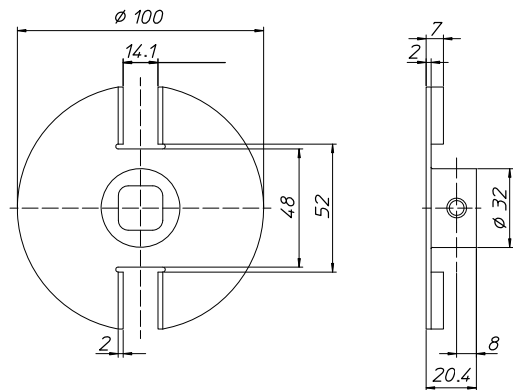

Drives can be supplied in various dimensions and designs for different applications.

Dimensional drawing

Dimensional drawing rotary encoder with adapter flange (cover) GEL 2712

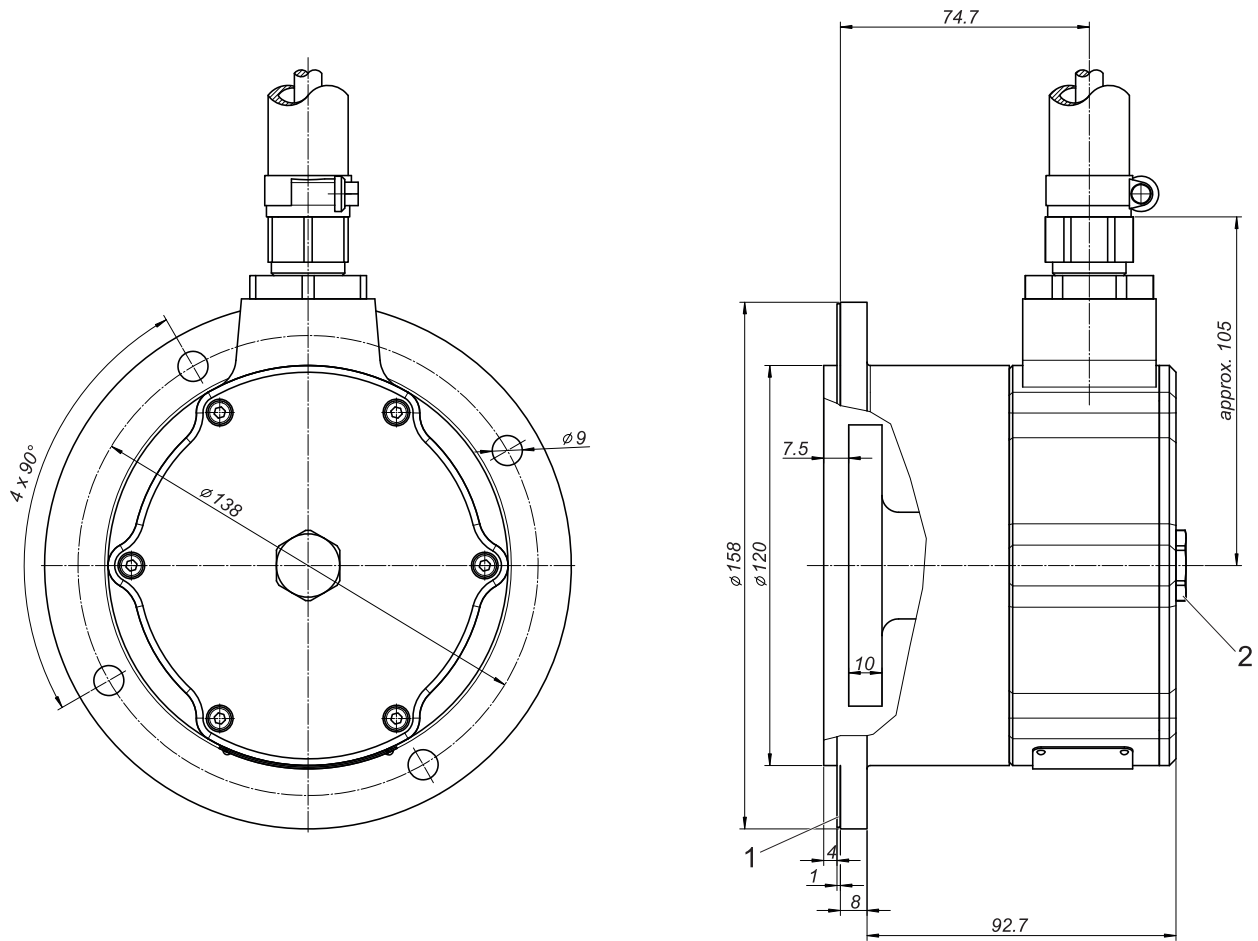

All dimensions stated in mm

- 1 Seal, thickness 1 mm
- 2 Blanking plug, SW 24

Torque support by fixing the cable hose

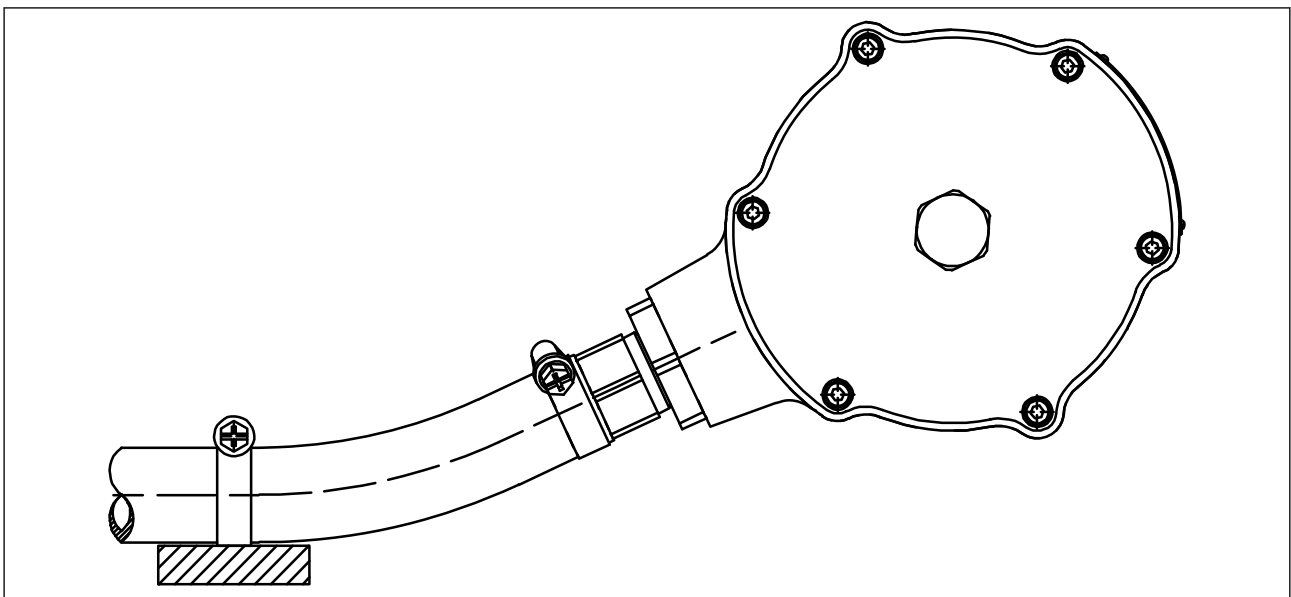

This document and contents are the intellectual property of Lenord, Bauer & Co. GmbH. Without the written consent of Lenord, Bauer & Co. GmbH, the disclosure and forwarding to third parties as well as any exploitation of the contents, including the registration of intellectual property rights, is prohibited.



Lenord, Bauer & Co. GmbH	Lenord+Bauer Italia S.r.l.	Lenord+Bauer USA Inc.	Lenord+Bauer
Dohlenstraße 32	Via Gustavo Fara, 26	32000 Northwestern Highway	Automation Technology (Shanghai) Co.,Ltd.
46145 Oberhausen	20124 Milano	Suite 150	Block 42, Room 302, No.1000, Jinhai Road
Germany	Italy	Farmington Hills, MI 48334	201206 Shanghai
Phone +49 (0)208 9963-0	Phone +39 340 1047184	USA	China
www.lenord.de	www.lenord.com	Phone +1 248 446 7003	Phone +86 21 50398270
		www.lenord.com	www.lenord.cn